

# Bettis Series 2000 Aquanaught

Operate Submerged Actuator Confidently





# Table of Contents

## Section 1: Introduction

## Section 2: Features

## Section 3: Local Display Module

3.0.1 Operation.....	4
3.0.2 Local Operation.....	4
3.0.3 Operational Display.....	5
3.0.4 Alarms Display.....	6

## Section 4: Wiring

4.0.1 Power Wiring.....	7
4.0.2 SCM to AEE Wiring.....	7
4.0.3 Motor Wiring.....	7
4.0.4 Sensor and Limit Switch Wiring.....	7

## Section 5: Limit Switch Settings

5.0.1 Limit Switch Setting Instructions.....	8
5.0.2 Torque Seated Valves.....	11
5.0.3 Torque Switch Calibration.....	11

## Section 6: Electronics Setup

6.1 Alarm History Display.....	14
6.2 Setup Mode Display Sequence.....	15
6.3 Analog Output Calibration.....	17
6.4 Factory Setup Mode.....	17
6.4.1 Emergency Shut Down (ESD) Setup.....	18
6.4.2 Torque Seat Setup.....	18



# Section 1: Introduction

## **WARNING**

Failure to follow instructions for proper electrical wiring, storage, setup, and maintenance may cause serious injury, damage equipment, or void the warranty. Refer to Manual E796 for instructions on storage, electrical hook-up, and maintenance.

---

The Aquanaught Series 2000 actuator is intended for use in either marine water or waste water applications where a portion or the entire valve actuator may be placed under water for periods of time, typically during plant flooding conditions.

## Section 2: Features

The actuator features several assemblies as listed below – refer to Figure 1.

- LDM – Local Display Module: Contains actuator micro-processor which monitor the system health and indicate the control feedback.
- SCM – Separate Control Module: Houses electrical controls to include optional inverse time Circuit Breaker, Overload Relay and Spacer Heater.
- MCB – Motor Conduit Box: Cover threaded with o-ring seal to prevent water entry. Motor wire splicing with hermetically sealed connectors for ease of motor removal and installation.
- AEE – Actuator Electric Enclosure: Houses both Position & Torque switches with hermetically sealed electrical contacts for positive operation. Includes encapsulated sealed non-contacting absolute position encoder (hall effect sensor) for valve position feedback. Each component has its own hermetically sealed connectors for ease of maintenance and installation.
- 2" AWWA Nut with Torque Limiter: Optional vertical drive system allows operator to hand drive the valve actuator in case of electrical failure. The adjustable torque limiter will be included to prevent from over-torque.

Figure 1

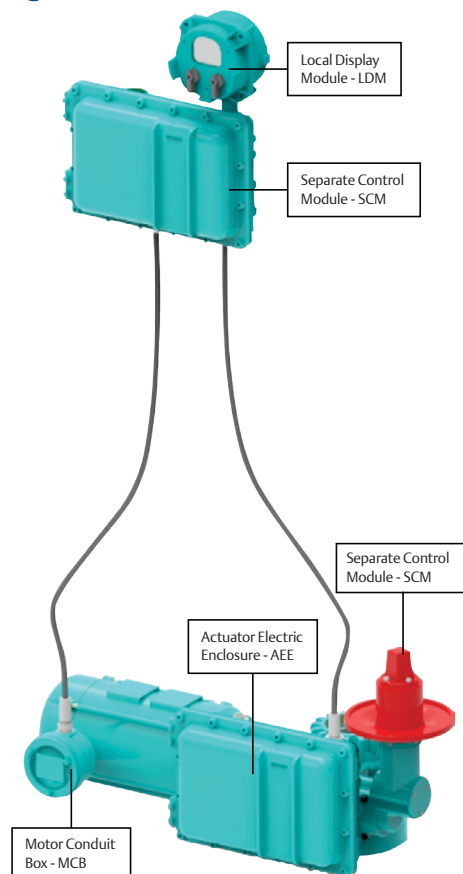
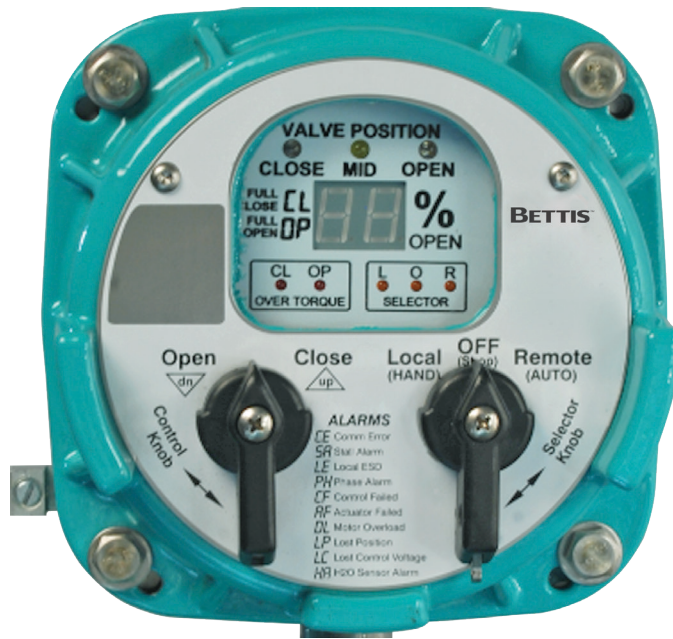

Figure 2



## Section 3: Local Display Module

Contains micro-processor controller. This is the main controller used to setup and operate the actuator.

This module displays operating parameters, valve position, and alarms, and provides for configuration of the actuator controls.

To use the Local Control and Selector Knobs refer to the following table.

**Table 1.**

Selector Knob (right)	Rotate	Function	Results
OFF (Stop)	[return position]	Stop Movement	Prevents motor operation.
REMOTE (Auto)	Clockwise	Remote Control	Allows control from remote location.
LOCAL (Hand)	Counter - clockwise	Hand Operation	Allows control from the local control knob or the control knob of the RDM, if connected.
(while selector is in LOCAL [hand] mode)			
Control Knob (left)	Rotate	Function	Results
Spring return	Neutral position	No operation	Releases a local command when Local control mode is configured for maintainance
CLOSE (UP)	Clockwise	Local command to close valve	Commands valve to move in the close direction
OPEN (DOWN)	Counter - clockwise	Local command to open valve	Commands valve to move in the open direction

### 3.0.1 Operation

Place the “Selector Knob” in the desired operating position.

LOCAL – used for hands on operation of the actuator by manipulation of the Control Knob.

REMOTE – used within the context of plant operation, i.e. Remote Control Panel, PLC, DCS, etc. See wiring diagram for typical user wiring for remote control.

### 3.0.2 Local Operation

Place the “Selector Knob” in the “Local” position. If a remote display is connected, the remote selector switch must not be in the “Off” position. Verify that the selector “L” amber light is on. The actuator may now be operated with the local Control Knob.

To Open the valve, rotate the control knob in the counterclockwise direction to the Open direction.

To Close the valve, rotate the control knob in the clockwise direction to the Close direction.

To Stop the valve, momentarily rotate the control knob in the opposite direction of travel or move the Selector knob to the OFF (Stop) position.

### 3.0.3 Operational Display

Valve position indication for Close / Mid Stroke / Open position is through use of long lasting LED's. Percentage of Open or Close is shown on the digital readout during normal operation & displayed on the readout as either "OP" when full Open or "CL" when full Close.

CLOSE LED flashes while the valve is moving in the close direction.  
It is steady on while the valve is fully closed.

OPEN LED flashes while the valve is moving in the open direction.  
It is steady on while the valve is fully open.

MID (Yellow) LED is steady on while the valve is stopped in mid-travel.  
This yellow LED flashes when an alarm is present.

OVER TORQUE alarm conditions are indicated for both Open and Close direction of operation. When a torque alarm occurs in mid-travel, the over torque LED will flash for the direction of travel. When the valve is torque seated, the CL over torque LED will remain steady on.

Selector switch LEDs are also made available for operational use in the bottom right corner. The selector LEDs are important when using a Remote Display Module (RDM) because these LEDs indicate the combined logic of the two selector switches, i.e. the selected mode of operation of the actuator.

Figure 3

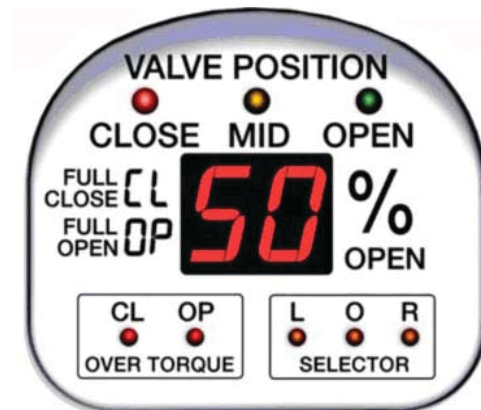

**NOTE:**

Color of the Close and OPEN LEDs may be reversed in setup mode.

### 3.0.4 Alarms Display

When an alarm occurs, it is automatically displayed by the two character LED display. The yellow MID LED will flash while any alarm is present. The display will alternate between the current position and the active alarm(s). If more than one alarm is active, the display will cycle through a sequence of valve Position, newest alarm, Position, next oldest alarm and so on until all active alarms are displayed. The cycle is continuously repeated until all alarms are cleared. Each alarm is recorded in an Alarm History. The alarm history may be viewed by entering setup mode (see next section).

All possible alarms that may be displayed are listed on the name plate of the display Local Display Module (LDM). Following are definitions of the listed alarms.

<b>CE</b>	<b>Communication Error</b>	Lost communication with the Remote Display Module (RDM) when configured.
<b>SA</b>	<b>Stall Alarm</b>	Actuator failed to move within 8 seconds after commanded by either local or remote controls.
<b>LE</b>	<b>Local ESD</b>	Hardwired Local Emergency Shut Down is active.
<b>PH</b>	<b>Phase Alarm</b>	Lost of one phase when configured for 3-Phase.
<b>CF</b>	<b>Control Failed</b>	Failure of the motor starter when sensed feedback does not match command.
<b>AF</b>	<b>Actuator Failed</b>	A fault is detected by hardware electronics fault monitor. This is a non-recoverable condition that requires actuator service.
<b>OL</b>	<b>Motor Overload</b>	Motor thermals or motor overload relay has tripped.
<b>LP</b>	<b>Lost Position</b>	Lost feedback from the Hall-effect Position Sensor (HPS) located in the AEE.
<b>LC</b>	<b>Lost Control Voltage</b>	Loss of power to the motor control circuits. The control voltage supply has an automatic resetting fuse.
<b>HA</b>	<b>H2O Sensor Alarm</b>	Water ingress into the electrical enclosure.

---

**NOTE:**

Over torque alarms are displayed by dedicated LEDs. See Operational Display section above.

---

## Section 4: Wiring

Refer to wiring diagrams located at the back of this manual for wiring connections. Refer on Figure 1 for location of enclosures and conduit entries. Use conduit and seals in accordance with National Electric Code (NEC) and local codes.

### 4.0.1 Power Wiring

Connect power voltage leads to the circuit breaker located in the SCM. Power wires must enter the SCM enclosure at the conduit entry on the lower right side of the SCM enclosure to prevent water from entering the enclosure. The controller provides automatic phase correction in case three phase power is connected in the wrong phase rotation.

### 4.0.2 SCM to AEE Wiring

Install conduits and seals between SCM and AEE as shown in the picture on Page 3 of this manual. After wiring is complete, all seals must be filled with a water proof sealing compound such as epoxy to prevent water from entering the AEE. Chico is not a waterproof sealant and is not acceptable to be used alone. Chico with epoxy poured on top is acceptable.

### 4.0.3 Motor Wiring

Connect three phase motor wires between the Motor Conduit Box (MCB) and the motor overload relay located in the SCM. Connecting to the proper phase is important. Connect two motor thermal wires between the MCB and SCM. Connect one motor thermal wire to terminal 96 of the motor overload relay and connect the other wire to terminal 1 of P7 (Motor Protector) located in the SCM.

### 4.0.4 Sensor and Limit Switch Wiring

The position sensor and limit switches use low voltage signals that should be protected and shielded from noise sources. Refer to wiring diagrams located at the back of this manual for point to point connections. Connect shielded triad cable (3 wires) between the HPS located AEE and connector P2 located on the TBM in the SCM. Use wire colors to ensure wires are connected to the correct points. The cable should be Belden 22660 or equivalent triad cable. Connect six wires between the limit switches, located in the AEE, and P1, located on the TBM in the SCM. Use shielded multi-pair cable such as Belden 22639 or equivalent cable with 3 twisted-pairs.

## Section 5: Limit Switch Settings

Set Open and Close valve travel and torque limits in the AEE before operating valve in automatic mode. Travel and torque limits are set using a common screw driver.

---

**NOTE:**

If electrical operation is used to move the valve while setting limits, stop movement short of the desired position and use hand wheel to complete valve travel.

---

### 5.0.1 Limit Switch Setting Instructions

1. Insert screwdriver in the Open setting slot shown in Figure 4. Use the hand wheel to open the valve part way. Note the rotation of the screwdriver.

---

**Figure 4**

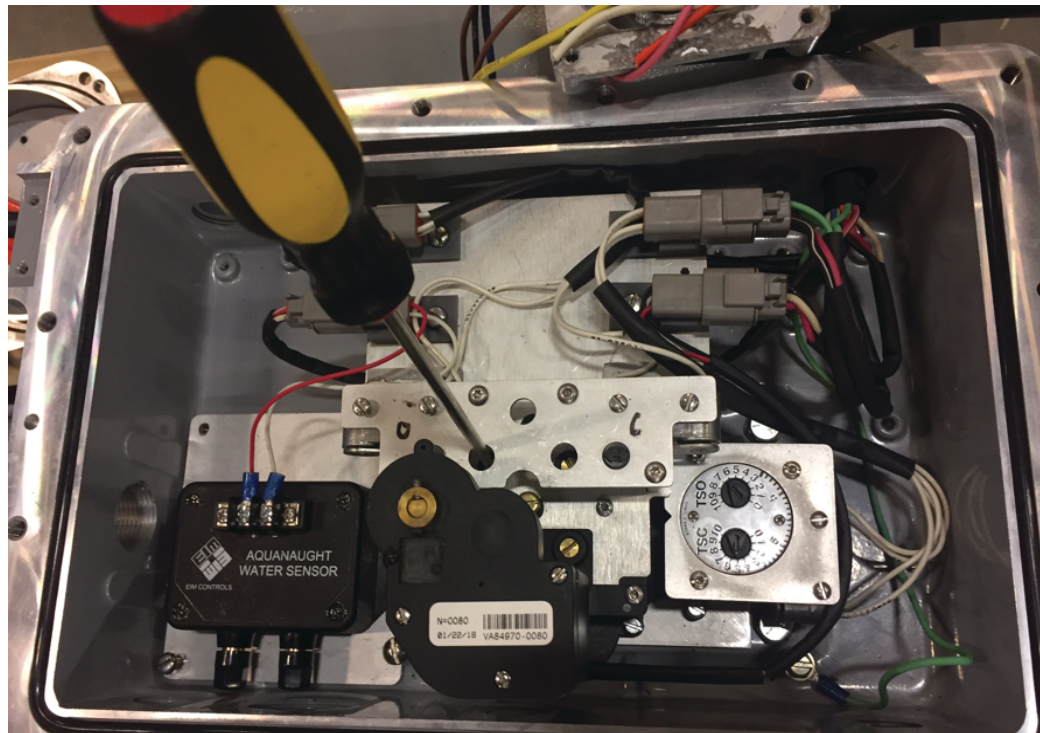

2. Place the screwdriver in the Close setting slot shown in Figure 5. Use the hand wheel to close the valve to the desired Close position. Note the rotation of the screwdriver while closing the valve.

Figure 5

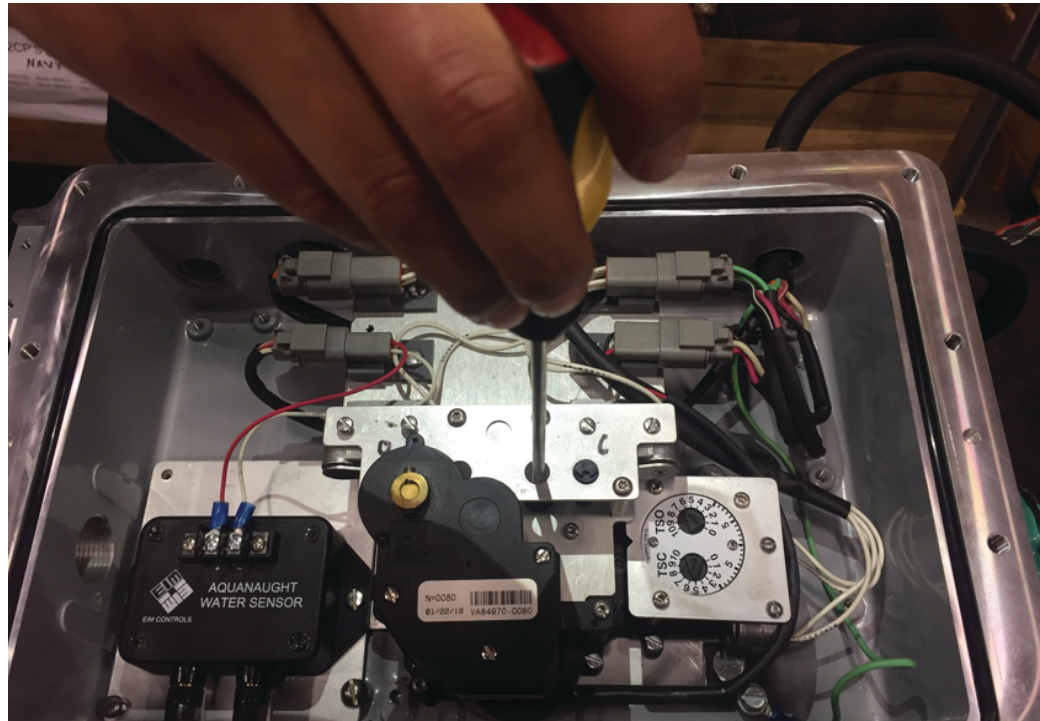

3. Insert the screwdriver in the Disengage Shaft slot as shown in Figure 6. Push the shaft down and rotate shaft 90°

Figure 6

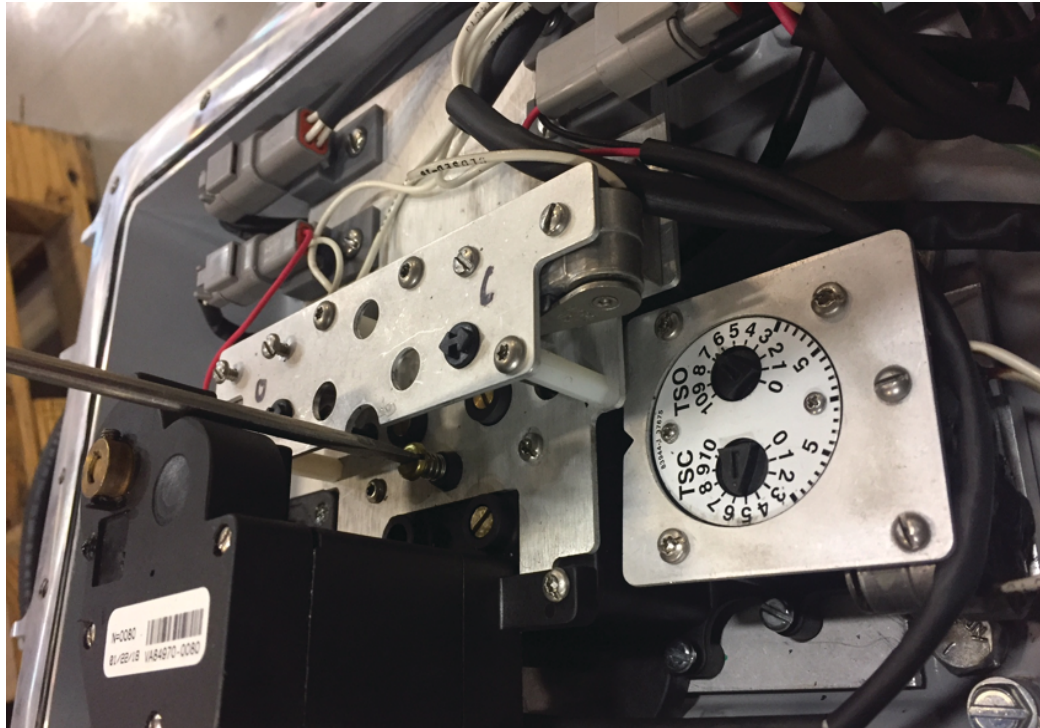

4. Use the screwdriver in the Close setting slot as shown in Figure 5. If the LSC switch rotor arrow does not line up vertically (within +15°), rotate screwdriver in same direction noted in Step 2 until switch just rotates.
5. Re-engage the spring-loaded drive gear by rotating disengage shaft shown in Figure 6. Spring loaded disengage shaft will rise.
6. Important: to insure limit switch gears have re-engaged properly with spring loaded drive gear, firmly “jiggle” (rotate) all adjustment shafts with screwdriver back and forth. Proper engagement has been made if all shafts will not turn with screwdriver.
7. Move valve to the desired Open position.
8. Set the Open travel limit switch by repeating steps 3) through 6) by substituting Open for Close. Place the screwdriver in the Open limit slot as shown in Figure 4 to adjust open limit switch.

## 5.0.2 Torque Seated Valves

If valve is torque seated and the geared limit contacts are used for indication only, the LSC (close limit) switch should be set several handwheel turns ahead of torque switch contact action. This gives proper valve position indication in spite of minor position variations which might occur due to torque seating. If torque seating is desired, DIP switches on the TBM must be set. See DIP switch setting on Section 6 of this manual. The electronics must also be configured for torque seat. See Electronics setup section.

## 5.0.3 Torque Switch Calibration

Refer to Figure 7 for location of torque dial within the AEE and the location of TSC and TSO adjustment slots.

Figure 7

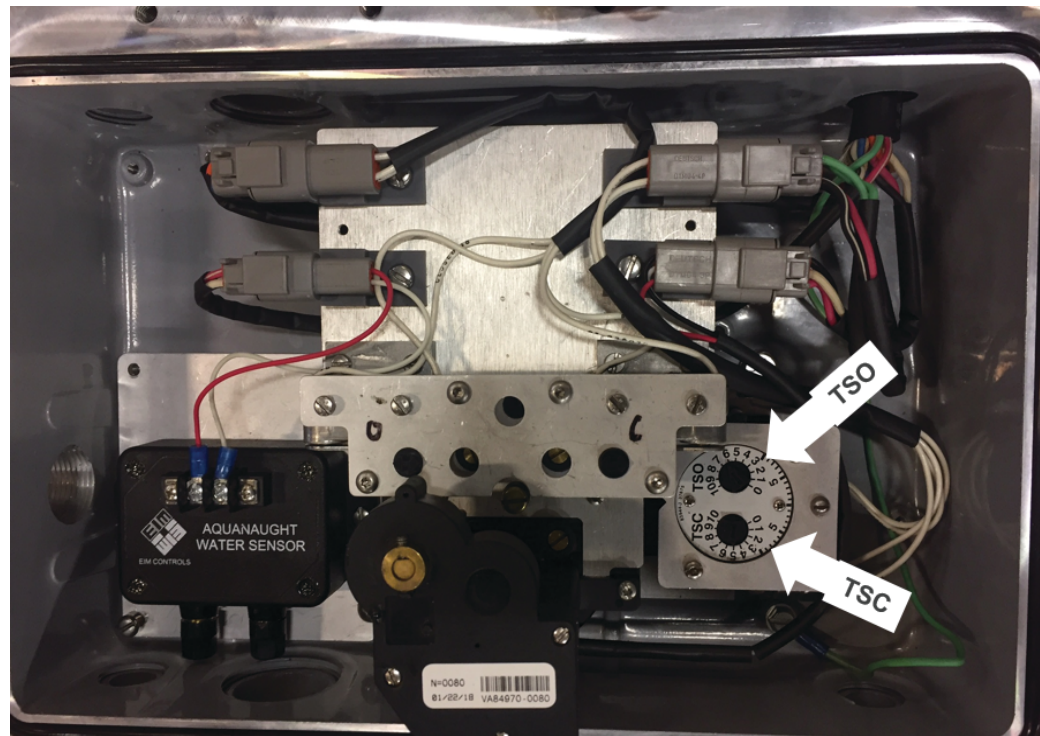

**To set Close Torque Switch (TSC)**

- a. Close valve using hand wheel. Set valve to desired torque. Observe rotating dial for number that corresponds to desired Close Torque.
- b. Insert screwdriver in TSC slot. Press down to disengage and turn arrow to setting determined in a). Release at this point and it will re-engage and remain set.
- c. Back the valve away from the Close position and reseat by hand wheel to verify torque trip point is at desired setting. The trip point of switch is a distinctive click as it breaks contact.

**To set Open Torque Switch (TSO)**

- a. Follow same procedure as for TSC at TSO dial.

## Section 6: Electronics Setup

Use the Local Control (left) knob and Selector (right) knob to enter setup mode and to execute Setup functions. The table below outlines the knob functions for Setup mode.

To access the electronics SETUP mode of operation, ensure the Selector Knob is placed in the OFF (Stop) position. Once set, rotate the Control Knob to the “UP” & then to the “DOWN” position in right to left succession three times. Keep the knob in each position for at least ½ second but not more than 3 seconds. The display module will flash the (3) amber selector LED’s when the SETUP mode is selected.

Figure 8

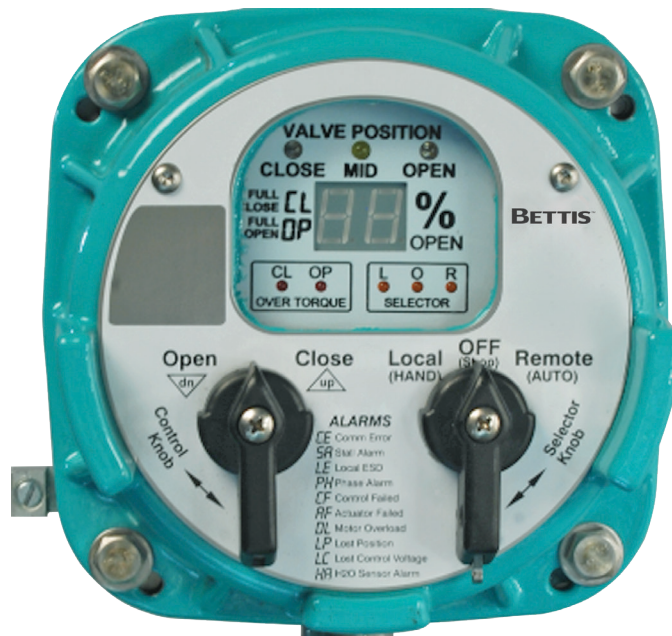

Table 2.

Selector Knob (right)	Setup Function	Setup Results
OFF (Stop) [return position]	Neutral Position	Allows entry to SETUP mode. Completes NEXT, or BACK entry cycle, except when knob is held for scrolling through various displays.
Clockwise (REMOTE) (Auto)	NEXT	Advances to the next display.
Counter - clockwise (LOCAL) (Hand)	BACK	Backs up to the last display.
(while selector is in LOCAL [hand] mode)		
Control Knob (left)	Setup Function	Setup Results
Spring return to center	Neutral Position	Completes UP of DOWN entry Cycle except when knob is held for continuous data entry update.
Clockwise (CLOSE)	UP	Increments displayed data.
Counter - clockwise (OPEN)	DOWN	Decrements displayed data.

When the actuator LDM is placed in SETUP mode of operation it first displays the Alarm History (AH) menu. The alarm history may be viewed without entering a passcode (See Alarm History Display section).

---

**NOTE:**

On any setup menu, use up/down to change a parameter and back/next to accept the displayed parameter. All menus and all parameters are wrap around, meaning they will advance from the highest or last value to the lowest or first value.

---

To view or change setup parameters of the actuator, Rotate the Selector Knob to the right or NEXT position to cycle through the alarm history display A1 through A8 until P1 is displayed. Alarm history (A1-A8) may be skipped by changing AH(1) to AH(0) and go directly to passcode menu.

Passcode menu is displayed as two, two-digit entries, P1 and P2. The actuator is shipped from the factory with the passcode disabled, meaning that the passcode is 00 00. Until the passcode is changed by the user, the passcode of 00 00 may be accepted by using the NEXT selector knob sequence to accept the passcode and continue to the setup menus. You will now be able to display and/or edit setup data.

---

**NOTE:**

While in the SETUP mode the actuator will not turn on the motor control circuits & disables all control of discrete outputs until exiting the Setup Mode.

---

## 6.1 Alarm History Display

Setup always enters the main menu at the Alarm History (AH). The user may view the alarm history without having to enter a passcode. The AH menu will alternately display a value of 0 or 1. Use the Control Knob up or down to change the selection from 0 to 1 or 1 to 0. If display of the alarm history is desired, then the value must 1. When AH with a value of 1 is displayed, use the Selector Knob REMOTE (NEXT) to advance through the alarms. If it is desirable to skip the alarm history and advance to the setup menus, use the control knob to select a value of 0 and then the Selector Knob Remote (NEXT) to advance directly to the P1 passcode entry.

Alarms in the alarm history are displayed by a sequence number A1 through A8. The display alternates between the alarm sequence number (A1-A8) and the recorded alarm. A1 is the newest alarm and A8 is the oldest alarm. Use the NEXT and BACK selector positions to cycle through the alarms. Blanks are displayed for fewer than 8 alarms. The alarm history is cleared by cycling power to the actuator. If it is desirable to only display alarm history and not go into setup, use the LOCAL (BACK) selection repeatedly to back out of the alarm history and return to normal operating mode.

## 6.2 Setup Mode Display Sequence

The three (3) amber LED's for the LOR section flash to indicate Setup Mode. When in setup mode, the user must enter the REMOTE (NEXT) or LOCAL (BACK) within 120 seconds or the display will revert back to the normal display mode.

Setup data may be changed by using the UP & Down entries of the Control Knob. The UP and Down entries are active only after a valid pass-code is entered and the Selector Switch is in the STOP position. The default pass-code is P1 00 and P2 00. Once the correct passcode is entered and accepted at the actuator controls, the user will then be able to advance thru the displays shown in the Main Menu table on the following page.

The table on the following page shows the sequence of the setup menus. It also shows the selections, units, and defaults. Each time the REMOTE (NEXT) selector knob is selected, the display advances to the next menu item. Each time the LOCAL (BACK) selector knob is selected, the display backs up to the previous menu item. The UP and DOWN control knob is used to increment or decrement the value shown in the table.

Following is an example for selecting a new control mode. In this example the current mode is 2 for 3-Wire Maintained and we want to change it to 4-Wire mode.

1. Enter setup mode – Selector knob Off – Rock control knob back and forth until 3 selector LEDs begin to flash and AH is displayed. When using the selector knob to advance to the next menu or back to the previous menu, always return the selector to the Off position to complete the cycle.
2. Use control knob to change the value of AH to 0 – Rotate selector knob clockwise to Remote (Next) to display P1 (1st passcode). The display will alternate between P1 and the value (default is 00). If the passcode had been changed, rotate the control knob clockwise to advance the display to the correct 1st passcode. Rotate the selector knob clockwise to advance to the next display, P2. The display will alternate between P2 and value of the 2nd passcode (default is 00). If the passcode had been changed, rotate the control knob clockwise to increment the display to the correct 2nd passcode.
3. Rotate the selector knob clockwise to advance to the next menu item, C0, “Control Mode” selection. The display will alternate between C0 and the value of C0 which we assumed to be 2.
4. Rotate the control knob clockwise to the up position and allow to spring return. Repeat if necessary until a value of 3 is displayed. If a value greater than 3 is displayed then rotate the control knob to the down position to decrease the value until 3 is displayed.
5. Repeatedly cycle the selector knob to the Remote (Next) position and the Off position to advance through the remaining menu items until the EP (Exit Program) is displayed.
6. If it is desirable to exit, use the control knob Up or Down to display a 1 value. Use the selector knob Remote (Next) to select exit. The system and display will return to normal operating mode.

---

### NOTE:

Use Selector Knob to select Menu and Use Control Knob to select Units.

---

Table 3.

Menu	Parameter	Value	Units	Default
AH	Display Alarm History?	0-1	0=No, Skip to 1st Passcode	
	1=Yes, Display History			
A1	1st older alarm	Alarm	None	
A2	2nd older alarm	Alarm	None	
A3	3rd older alarm	Alarm	None	
A4	4th older alarm	Alarm	None	
A5	5th older alarm	Alarm	None	
A6	6th older alarm	Alarm	None	
A7	7th older alarm	Alarm	None	
A8	8th older alarm	Alarm	None	
P1	1st passcode	00-99	None	00
P2	2nd passcode	00-99	None	00
C0	Control Mode	1-4	1=2-Wire	
	2=3-Wire Maintained			
	3=4-Wire			
	4=3-Wire Momentary	3		
C1	Modulation delay	1-60	Seconds	1
C2	Local Seal-ins	0-1	0=Off, 1=On	0
C3	Rotation to Close	0-1	0=CCW, 1=CW	0
C4	LED colors	0-1	0=Open Grn/Close Red	
	1=Open Red/Close Grn	1		
C5	Torque Seat	0-1	0=Position seat	
	1=Torque seat	0		
C6	Torque Backseat	0-1	0=Position backseat	
	1=Torque backseat	0		
C7	ESD Action	0-3	0=Stop/Stayput	
	1=Open			
	2= Close			
	3=Go to Position	0		
C8	ESD Position	CL,1-99,OP	% open	CL
E0	Duty Cycle Period	0-99	Seconds	0
E1	Open Speed Start Pos	CL,1-99,OP	% open	OP
E2	Open Speed Reduction	0-99	% speed	0
E3	Close Speed Start Pos	CL,1-99,OP	% open	CL
E4	Close Speed Reduction	0-99	% speed	0
E5	Anti-Water Hammer Start	CL,1-99,OP	% open	10
E6	Anti-Water Hammer Speed Reduction	0-99	% speed	0
E7	Edit 1st Passcode	00-99	None	00
E8	Edit 2nd Passcode	00-99	None	00
a0	AO Zero Calibration	blank	Approx. 0.023mA	4mA
a1	AO Full Scale Cal.	blank	Approx. 0.023mA	20mA
EP	Exit Program?	0-1	0=No, Return to last menu	

## 6.3 Analog Output Calibration

Analog position feedback is a loop powered 4-20mA output. Power must be supplied to the loop from an external loop supply. The 24VDC power available at terminals 6 and 7 of Connector P3-1 may be used to power the loop. The 4-20mA analog output may be calibrated to the user’s standard by using the following steps.

1. Connect a current meter in the 4-20mA loop as shown in the “Typical User Wiring Diagram” on Page 18 of this manual.
2. Move the valve to the closed position. If motor operation is available, move the valve in the close direction until the close limit trips.
3. If the current reading on the current meter is not within desired tolerance of 4mA, go into Electronics Setup mode and advance to menu “a0”. Use the Up control knob function to increase the current by approximately 0.023mA for each increment. Use the Down control knob function to decrease the current by approximately 0.023mA for each increment.
4. Move the valve to the open position. If motor operation is available, move the valve in the open direction until the open limit trips.
5. If the current reading on the current meter is not within desired tolerance of 20mA, go into Electronics Setup mode and advance to menu “a1”. Use the Up control knob function to increase the current by approximately 0.023mA for each increment. Use the Down control knob function to decrease the current by approximately 0.023mA for each increment.

## 6.4 Factory Setup Mode

Factory setup mode is available only to factory representatives using a special passcode. The following table is provided only for information. The user should not attempt to enter this mode.

**Table 4. Factory Setup Table**

Menu	Parameter	Value	Units	Default
F0	Reset User Passcode	0-1	0=Do nothing 1=Restore passcode to 00 00	0
F1	Starter Type		0=Electromechanical 1=Solid State Relay	0
F2	Phases	0-1	1=Single phase power 3=Three phase power	3
F3	RDM Required		0=Not req., 1=Required	0

## 6.4.1 Emergency Shut Down (ESD) Setup

Local ESD is a hardware circuit within the Local Display Module that will detect an externally wired closed loop circuit connected to Terminals 5 and 7 of P3-1. When an open circuit is detected the local ESD is activated. Valve operation is determined by dip-switch settings on the back of the terminal board in the Separate Control Module. When SW1 is “ON” the valve will go close on an ESD signal. When SW2 is “ON” the valve will go open on an ESD signal. When S1 & S2 are on the actuator will Inhibit operation, and stay put. The Local hardwired ESD when set by the DIP switches overrides microprocessor controlled electronics and forces the valve to the desired state selected by the DIP switches.

Figure 9

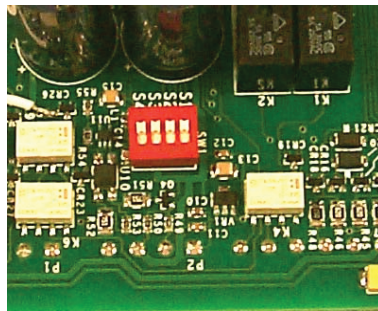

## 6.4.2 Torque Seat Setup

In addition to configuring the actuator electronics with the control knobs, hardware setup is required. To select torque seating a valve, set both S3 & S4 to the ON position. Turn off both S3 & S4 for position seat.

Figure 10 Wiring Diagram

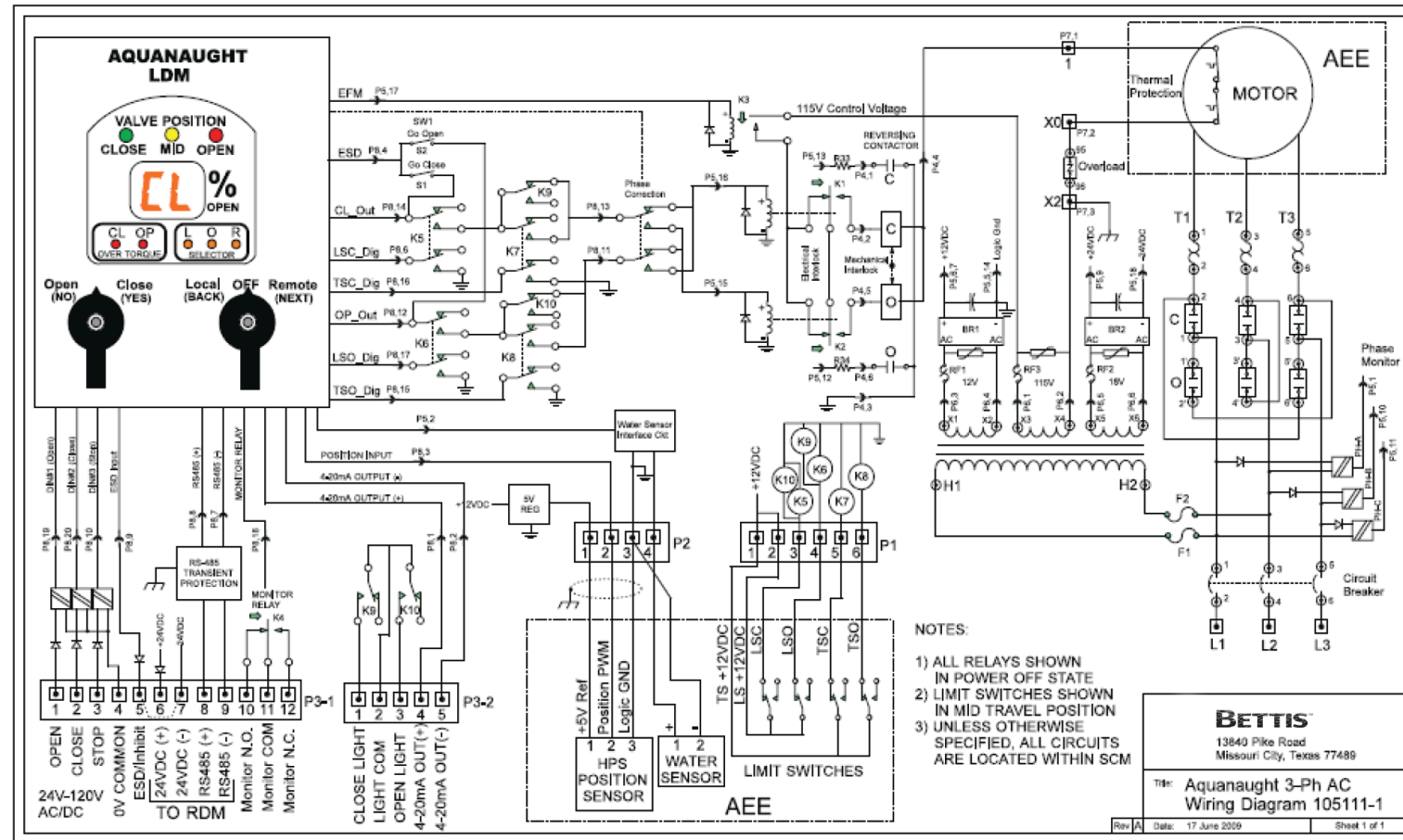
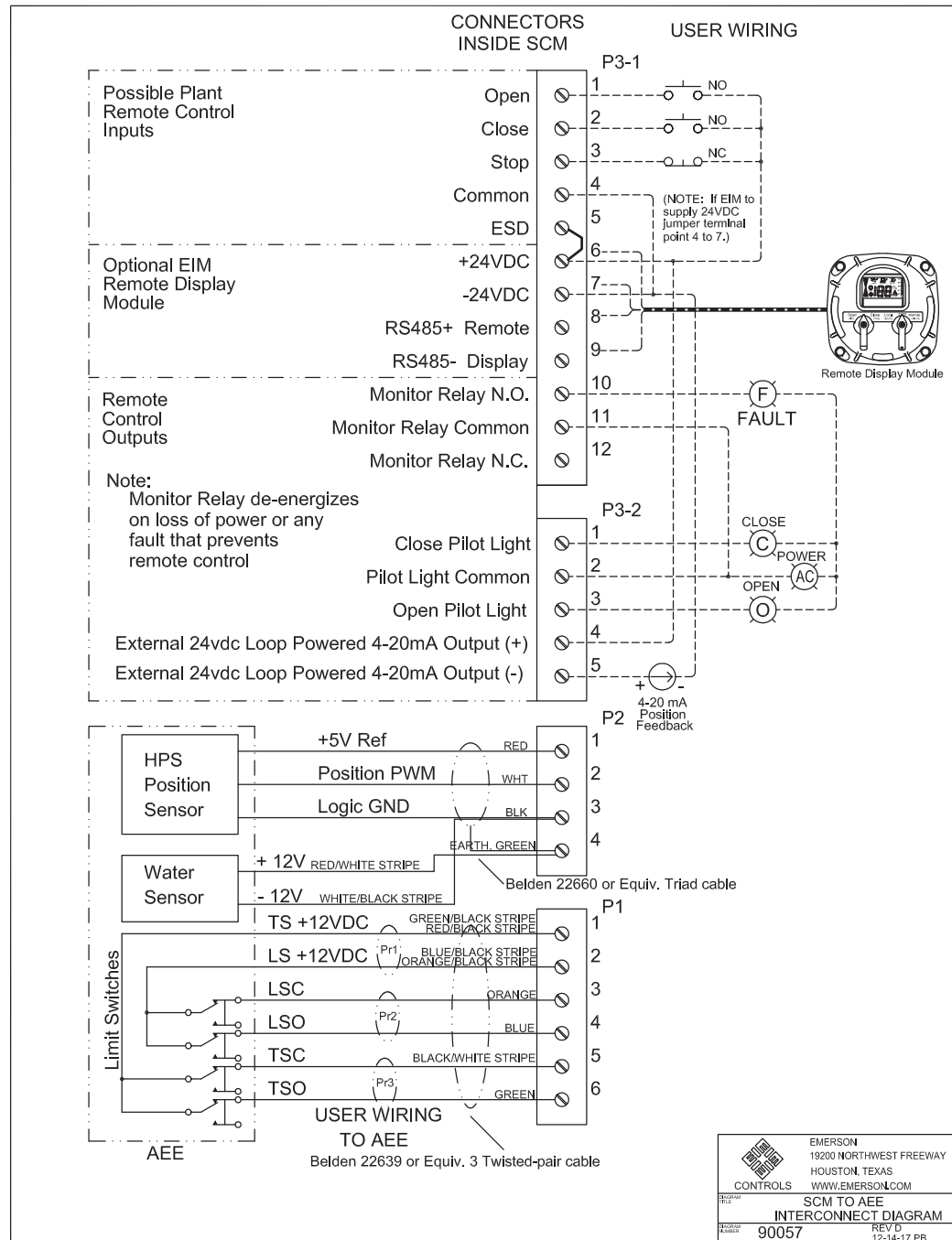

Figure 11 Typical User Wiring Diagram





**World Area Configuration Centers (WACC) offer sales support, service, inventory and commissioning to our global customers. Choose the WACC or sales office nearest you:**

***NORTH & SOUTH AMERICA***

19200 Northwest Freeway  
Houston TX 77065  
USA  
T +1 281 477 4100

Av. Hollingsworth  
325 Iporanga Sorocaba  
SP 18087-105  
Brazil  
T +55 15 3413 8888

***ASIA PACIFIC***

No. 9 Gul Road  
#01-02 Singapore 629361  
T +65 6777 8211

No. 1 Lai Yuan Road  
Wuqing Development Area  
Tianjin 301700  
P. R. China  
T +86 22 8212 3300

***MIDDLE EAST & AFRICA***

P. O. Box 17033  
Jebel Ali Free Zone  
Dubai  
T +971 4 811 8100

P. O. Box 10305  
Jubail 31961  
Saudi Arabia  
T +966 3 340 8650

24 Angus Crescent  
Longmeadow Business Estate East  
P.O. Box 6908 Greenstone  
1616 Modderfontein Extension 5  
South Africa  
T +27 11 451 3700

***EUROPE***

Holland Faszor 6  
Székesfehérvár 8000  
Hungary  
T +36 22 53 09 50

Strada Biffi 165  
29017 Fiorenzuola d'Arda (PC)  
Italy  
T +39 0523 944 411

For complete list of sales and manufacturing sites, please visit [www.emerson.com/actuationtechnologieslocations](http://www.emerson.com/actuationtechnologieslocations) or contact us at [info.actuationtechnologies@emerson.com](mailto:info.actuationtechnologies@emerson.com)

[www.emerson.com/bettis](http://www.emerson.com/bettis)

VCIOM-13502-EN ©2019 Emerson. All rights reserved.

The Emerson logo is a trademark and service mark of Emerson Electric Co. Bettis™ is a mark of one of the Emerson family of companies. All other marks are property of their respective owners.

The contents of this publication are presented for information purposes only, and while every effort has been made to ensure their accuracy, they are not to be construed as warranties or guarantees, express or implied, regarding the products or services described herein or their use or applicability. All sales are governed by our terms and conditions, which are available on request. We reserve the right to modify or improve the designs or specifications of our products at any time without notice.

**BETTIS™**

