

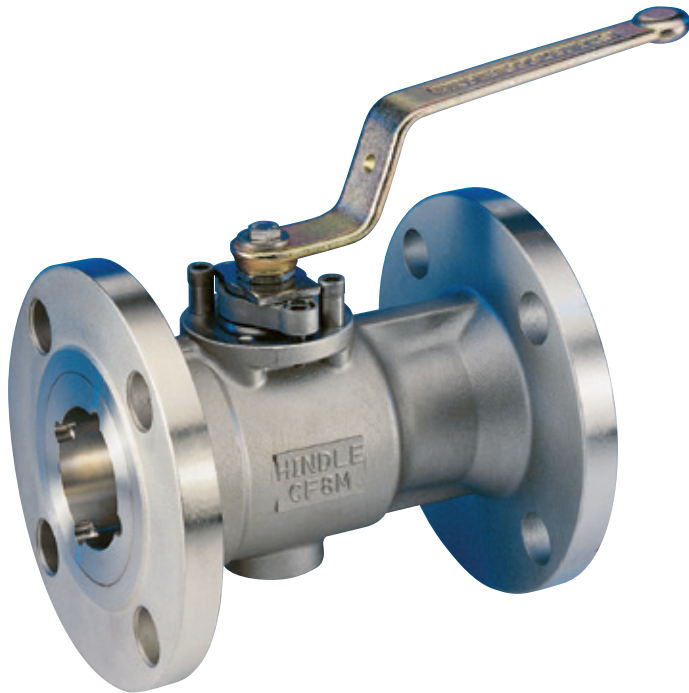

KTM HINDLE SERIES 110 AND 200 ULTRA-SEAL BALL VALVES

A range of one piece reduced bore, flanged, free floating (seat supported) ball valves, incorporating mounting flanges to BS EN ISO 5211, featuring soft, metal and carbon seated designs



FEATURES

- One piece reduced bore body, flanged construction in carbon steel, stainless steel and special alloys.
- Compact body design with minimum weight and elimination of potential leak path.
- Designed in accordance with ASME B16.34, BS EN ISO 17292 and ISO 14313/API 6D.
- Floating ball design for bi-directional shut-off.
- Flexing soft seat design for superior shut-off across a range of pressures with minimum operating torque.
- Low temperature and cryogenic designs for service down to -196°C available on request.
- Spring energized metal and carbon seat designs permitting tight shut-off and positive cavity pressure relief.
- Fused hard nickel alloy, chromium carbide or tungsten carbide coated seat and ball designs for abrasive and high temperature service.
- Hard carbon seat design for medium temperature applications.
- High integrity shaft seal minimizing the potential for atmospheric leakage.
- Fugitive emission performance to BS EN ISO 15848-2 class A.
- Corrosion resistant trim. Standard valves incorporate balls and shafts of stainless steel for long service life.
- Fire test certified. All sizes and pressure ratings are covered by approved certification.
- Anti-static and blow-out proof shaft design.
- Most designs offer cavity pressure relief to upstream in event of thermal expansion.
- Could be integrated into a SIL 3 environment safety instrumented system.

GENERAL APPLICATIONS

There are two separate design types within the one piece Ultra-Seal range, depending upon valve size:

- Series 110 reduced bore
- Series 200 reduced bore

A range of two piece Series 300 Ultra-Seal full bore valves are also available.

TECHNICAL DATA

Sizes: Series 110 reduced bore
NPS ½ - 2 (DN 15 - 50)

Series 200 reduced bore
NPS 3 - 10 (DN 80 - 250)
NPS 12 - 16 (DN 300 - 400)
available on request



KTM HINDLE SERIES 110 AND 200 ULTRA-SEAL BALL VALVES

VALVE APPLICATIONS

Ultra-Seal ball valves are ideally suited for use in a wide variety of industries including petrochemical, chemical, oil and gas, LNG and marine with a choice of seat designs.

PTFE Seat applications	Cryogenic temperatures down to -196°C and non abrasive services up to 230°C depending on the grade of material. Vacuum service down to 0.1 mbar.A
Carbon Seat applications	Clean service from -20°C up to 300°C, suitable for use with organic solvents. Ideally suited for Purified Terephthalic Acid (PTA)
Metal Seat applications	Clean or Abrasive services from -50°C up to 450°C and/or applications where positive cavity relief is required together with bi-directional flow

Soft seat valve sizes NPS 12 - 16 (DN 300 - 400) available on request.

Metal/carbon seated valve sizes NPS ½ - ¾ (DN 15 - 20) available in 2-piece Series 300 full bore.

VALVE SEAT DESIGN RANGE

Class	Seat type	NPS ½ - ¾	NPS 1 - 2	NPS 3 - 6	NPS 8	NPS 10
		DN 15 - 20	DN 25 - 50	DN 80 - 150	DN 200	DN 250
150	Soft	✓	✓	✓	✓	✓
	Metal/carbon		✓	✓	✓	
300	Soft	✓	✓	✓	✓	✓
	Metal/carbon		✓	✓		

TECHNICAL SPECIFICATIONS

Design	BS EN ISO 17292 (BS 5351)	ISO 14313/API 6D ^[2]
	BS EN 1983	ASME B16.34
Face to face ^[1]	BS EN 558	ASME B16.10
Fire testing	BS 6755 Pt. 2	API 607
	BS EN ISO 10497	API 6FA
Pressure testing	BS ISO 5208	API 598
	BS EN 12266-1	ISO 14313/API 6D ^[2]
Material certification	BS EN 10204	NACE MR 0175-2002
		MR0103 and ISO 15156-2:2003 on request
Quality assurance	EN 29001	
	BS EN ISO 9001-2008	
ISO top mounting flange	BS EN ISO 5211	
	BS EN 15081	

NOTES

1. Long and short patterns available.
2. Conformity to ISO 14313/API 6D is limited to all class 150 valves and class 300 up to NPS 8 (DN 200).

STANDARD OPERATOR FOR SOFT SEATS

Class	NPS	DN	Lever	T-Bar	Gearbox
			Class 150	½ - 4	15 - 100
Class 300	½ - 3	15 - 80	4 and 6	8 and 10	200 and 250
	DN				

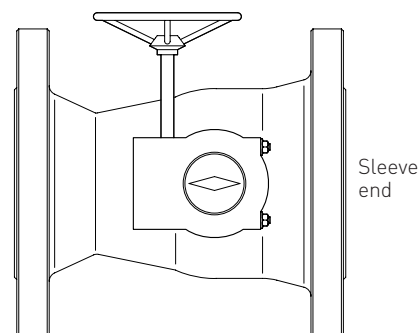

KTM HINDLE SERIES 110 AND 200 ULTRA-SEAL BALL VALVES

FACE TO FACE STANDARD ASME B16.10/BS EN 558 CLASS 150

NPS	DN	Short	Long
1/2 - 1 1/2	15 - 40	✓	✓
2	50	✓	✓
3	80	✓	✓
4	100	✓	✓
6	150	✓	
8	200	✓	
10	250	✓	

FACE TO FACE STANDARD ASME B16.10/BS EN 558 CLASS 300

NPS	DN	Short	Long
1/2 - 1 1/2	15 - 40	✓	✓
2	50	✓	✓
3	80	✓	✓
4	100	✓	✓
6	150	✓	✓
8	200	✓	
10	250	✓	

NOTE

These tables identify the standard face to face length of Ultra-Seal ball valves. Alternative pattern lengths are available on request.

SOFT SEATED DESIGN FEATURES

Ultra-Seal soft seated ball valves utilize PTFE seats for maximum chemical compatibility combined with minimum coefficient of friction.

Temperature range

Suitable for a range of non abrasive service temperatures between -196°C and 230°C, depending on the seat material.

Seat design

The seat rings incorporate a flexing design which ensures positive sealing across the pressure range, even at low differential pressures. Slots on the external diameter ensure pressure equalisation between the upstream and the valve cavity, reducing the load on the downstream seat and minimizing operating torques.

Seat leakage

Floating ball design provides tight shut-off in both direction to BS ISO 5208 rate A.

Fugitive emissions

High integrity shaft seals give low emission performance, even under thermal cycling. Tested and approved to Shell MESC SPE 77/312 class A for series 110 and class B for series 200. Meets the leakage performance of BS EN ISO 15848-2 class A.

METAL SEATED DESIGN FEATURES

Ultra-Seal metal seated ball valves incorporate proven metal seated technology together with advanced ball/seat coatings, spring materials and low emission seals.

Temperature range

Suitable for a range of service temperatures between -50°C and 450°C for fluids carrying abrasive particles and where positive cavity relief is required.

For temperatures above 300°C, heat dissipation bonnets are available for gland isolation outside lagging area. Refer to page 4 for minimum bonnet lengths.

Coatings

A range of ball and seat coating materials are available providing hardness values from 60 HRC up to 75 HRC and coating thicknesses between 500 µm and 200 µm.

Seat design

Body and seat design ensures controlled spring compression, giving optimum seat and seal performance, together with constant running torque. Spring and seat seals are protected from the main flowstream to prevent jamming and premature seat failure.

Seat leakage

The live loaded seat design gives reliable bi-directional sealing to BS ISO 5208 rate A in sizes up to DN 50, NPS 2 and rate B for DN 80, NPS 3 and above. Leak rates to ANSI/FCI 70-2 are also applicable to class VI up to DN 50, NPS 2 and class V for DN 80 and above.

Fugitive emissions

High integrity shaft seals give low emission performance, even under thermal cycling. Tested and approved to Shell MESC SPE 77/312 class A for series 110 and 200. Meets the leakage performance of BS EN ISO 15848-2 class A.

KTM HINDLE SERIES 110 AND 200 ULTRA-SEAL BALL VALVES

CARBON SEATED DESIGN FEATURES

Incorporating similar design technology to the metal seated range of ball valves, including spring materials and low emission seals.

Temperature range

Suitable for a range of service temperatures between -20°C and 300°C for use with clean organic solvents including PTA. Not recommended for fluids carrying abrasive particles. Heat dissipation bonnets are available for gland isolation outside lagging area.

Seat design

Carbon graphite seats are assembled into seat holders by thermal control fitting. This ensures correct support for the seat material throughout the service conditions.

Seat leakage

The live loaded seat design gives reliable tight shut off in both directions to BS ISO 5208 rate A.

Fugitive emissions

High integrity shaft seals give low emission performance, even under thermal cycling. Tested to Shell MESG SPE 77/312 class A for series 110 and 200. Meets the leakage performance of BS EN ISO 15848-2 class A.

CRYOGENIC SERVICE DESIGN FEATURES

KTM Hindle ball valves are recognized leaders in the field of low temperature and cryogenic applications, with more than twenty years experience in this specialized market sector. KTM Hindle experience includes many substantial international contracts for low temperature and cryogenic valves, including several large projects on Liquefied Natural Gas (LNG) plants, for major users and engineering contractors world-wide.

Ultra-Seal cryogenic ball valves are Type Approval Tested by Shell GSI and listed on Shell TAMAP database.

Extensions

A one-piece extension bonnet is fitted so as to relocate the shaft seal away from the cold area and to provide a pressurized column within which the cold liquid phase is changed, by heat transfer with the environment, to the gaseous phase. The extension also allows for the insulation of the valve body. KTM Hindle offer two extension lengths for each size of valve, in accordance with Shell specifications.

Cavity Relief

For temperatures below -50°C a pressure equalizing hole is provided in the ball at the upstream (sleeve end) of the valve, to provide positive cavity relief. This renders the valve uni-directional and the body is marked accordingly.

Operating Torque

Low temperature service requires higher operating torque and gearboxes may be required to replace lever operators. Since temperature is only one of the factors affecting operating torque, customers are advised to provide full application details with enquiries.

Drip Collars

Customers may specify the fitting of drip collars/trays, which minimize ice accumulation on the extension and prevent possible damage to lagging.

Acceptance testing

Dedicated in-house test facilities enable valves to be performance tested, at cryogenic temperatures, in accordance with major international standards or customer's individual requirements.

EXTENSION BONNET LENGTHS

Valve size			Extension length			
			-30°C to -109°C		-110°C to -196°C	
DN	NPS	Class	inch	mm	inch	mm
15 - 20	½ - ¾	150	4	100	8	200
		300	4	100	8	200
25 - 50	1 - 2	150	5	125	10	250
		300	5	125	10	250
80 - 100	3 - 4	150	6	150	12	300
		300	6	150	12	300
150 - 200	6 - 8	150	7	175	14	350
		300	7	175	14	350
100 - 200	4 - 8	150	8	200	16	400
		300	8	200	16	400

KTM HINDLE SERIES 110 AND 200 ULTRA-SEAL BALL VALVES

PARTS IDENTIFICATION SERIES 110 - REDUCED BORE SOFT SEATED

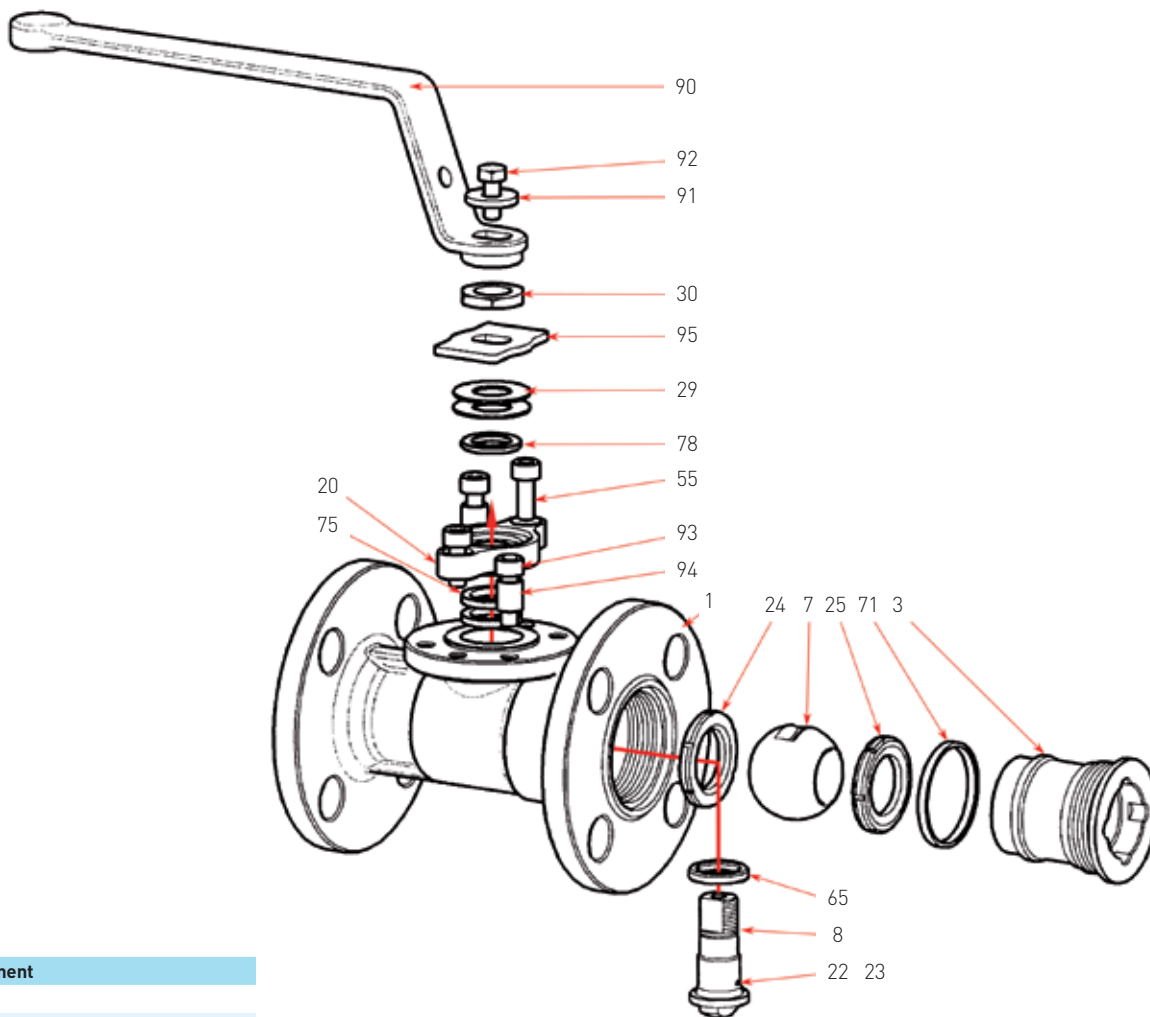

PARTS LIST

Item	Component
1	Body
3	Sleeve
7	Ball
8	Shaft
20	Gland
22	Shaft anti-static ball
23	Shaft anti-static spring
24	Body seat
25	Sleeve seat
29	Gland spring
30	Shaft nut
55	Gland screw
65	Shaft primary seal
71	Sleeve seal
75	Shaft fire seal
78	Wiper seal
90	Handlever
91	Handlever washer
92	Handlever screw
93	Stop screw
94	Stop collar
95	Stop plate

NOTES

- Standard materials of construction are given on page 14.

KTM HINDLE SERIES 110 AND 200 ULTRA-SEAL BALL VALVES

PARTS IDENTIFICATION SERIES 110 - REDUCED BORE METAL / CARBON SEATED

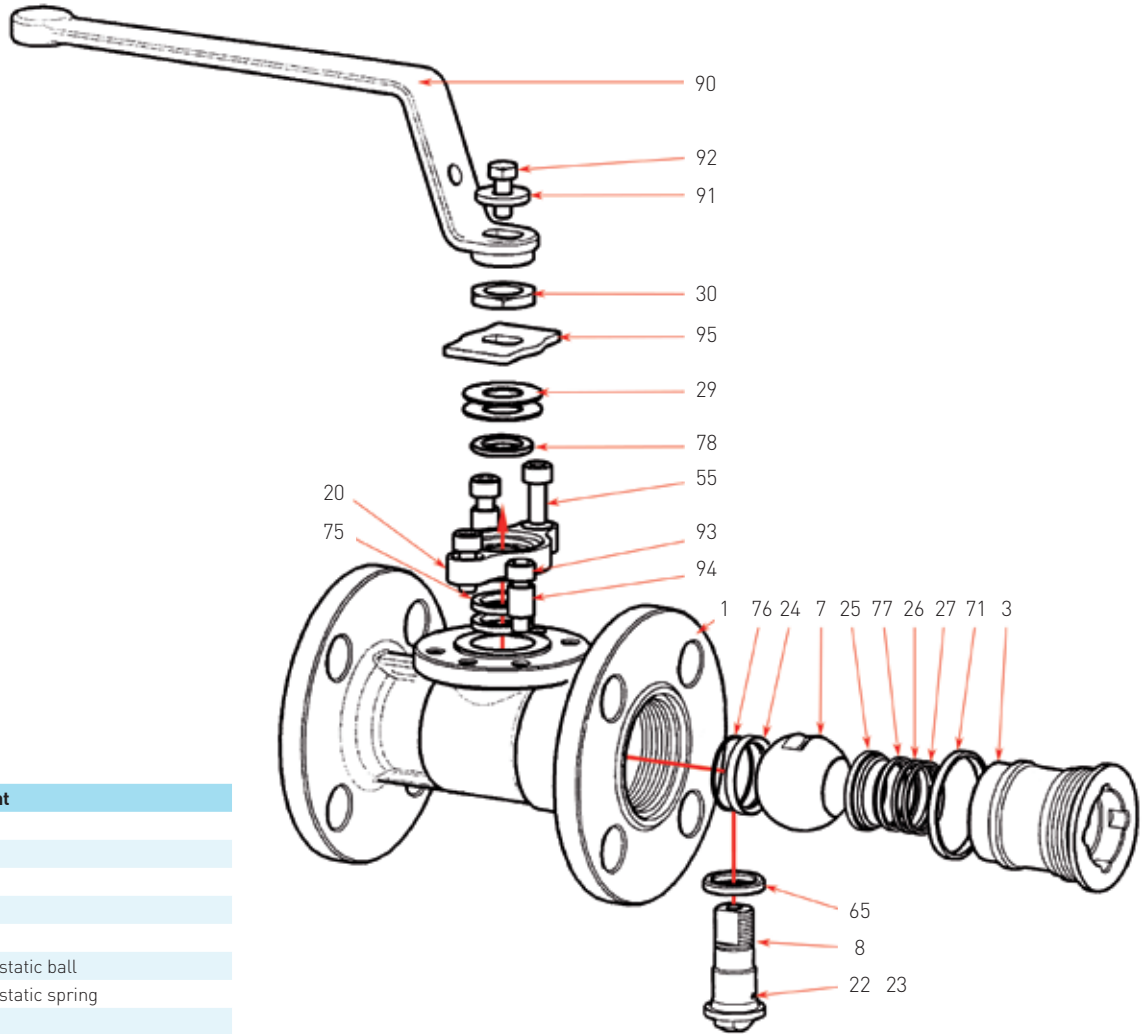

PARTS LIST

Item	Component
1	Body
3	Sleeve
7	Ball
8	Shaft
20	Gland
22	Shaft anti-static ball
23	Shaft anti-static spring
24	Body seat
25	Sleeve seat
26	Seat energizer
27	Seat spring
29	Gland spring
30	Shaft nut
55	Gland screw
65	Shaft primary seal
71	Sleeve seal
75	Shaft fire seal
76	Body seat seal
77	Sleeve seat seal
78	Wiper seal
90	Handlever
91	Handlever washer
92	Handlever screw
93	Stop screw
94	Stop collar
95	Stop plate

NOTES

- Standard materials of construction are given on page 14.
- Heat dissipation bonnets available for gland isolation outside lagging areas.

KTM HINDLE SERIES 110 AND 200 ULTRA-SEAL BALL VALVES

DIMENSIONS SERIES 110 - REDUCED BORE SOFT SEAT ILLUSTRATED

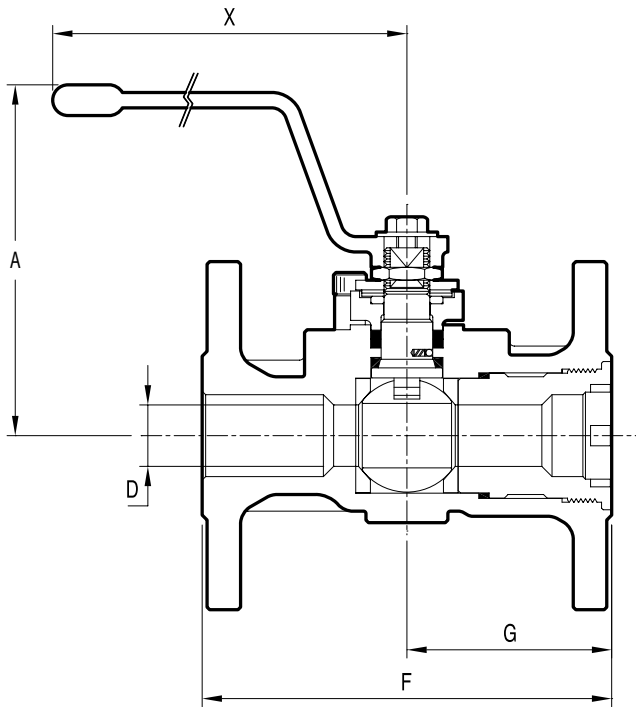

CLASS 150 - MODEL 115R CLASS 300 - MODEL 130R

Size NPS	DN	A		D		F				G		X		Weight (kg)	
		in.	mm	in.	mm	Class 150		Class 300		Class 150/300		in.	mm	Class 150	Class 300
1/2	15	3 ⁵ / ₈	92.1	3 ⁷ / ₈	9.5	4 ¹ / ₄	108.0	5 ¹ / ₂	139.7	2	50.8	5 ¹³ / ₁₆	147.6	1.5	2.3
3/4	20	3 ¹¹ / ₁₆	93.7	1/2	12.7	4 ⁵ / ₈	117.5	6	152.4	2 ¹ / ₈	54.0	5 ¹³ / ₁₆	147.6	2	3.3
1	25	4 ¹¹ / ₁₆	119.1	3/4	19.1	5	127.5	6 ¹ / ₂	165.1	2 ¹ / ₂	63.5	7 ¹ / ₂	190.5	3	4.5
1 ¹ / ₂	40	5 ¹ / ₁₆	128.6	1 ³ / ₁₆	30.2	6 ¹ / ₂	165.1	7 ¹ / ₂	190.5	2 ³ / ₄	69.9	7 ¹ / ₂	190.5	5	8.0
2	50	5 ⁵ / ₁₆	134.9	1 ⁷ / ₁₆	36.5	7	177.8	8 ¹ / ₂	215.9	2 ⁷ / ₈	73.0	7 ¹ / ₂	190.5	8	10.3

NOTES

Series 110

Size Range: Class 150/300 NPS 1/2 - 2 (DN 15 - 50)

1. All sizes have lever operator as standard.
2. Face to face dimensions (F in table) conform to ASME B16.10 and BS EN 558.
3. See page 14 for materials of construction.
4. Top mounting flange details are given on page 8.
5. Flange dimensions conform to ASME B16.5.

KTM HINDLE SERIES 110 AND 200 ULTRA-SEAL BALL VALVES

ISO FLANGE SIZE IDENTIFICATION

Valve sizes		Shaft sizes	
NPS	DN	150	300
1/2	15	6	6
3/4	20	6	6
1	25	7	7
1 1/2	40	7	7
2	50	7	7

NOTES

1. Topworks dimensions are determined according to the valve shaft size (Shaft size 6 or 7, see chart).

TOPWORKS DRAWINGS

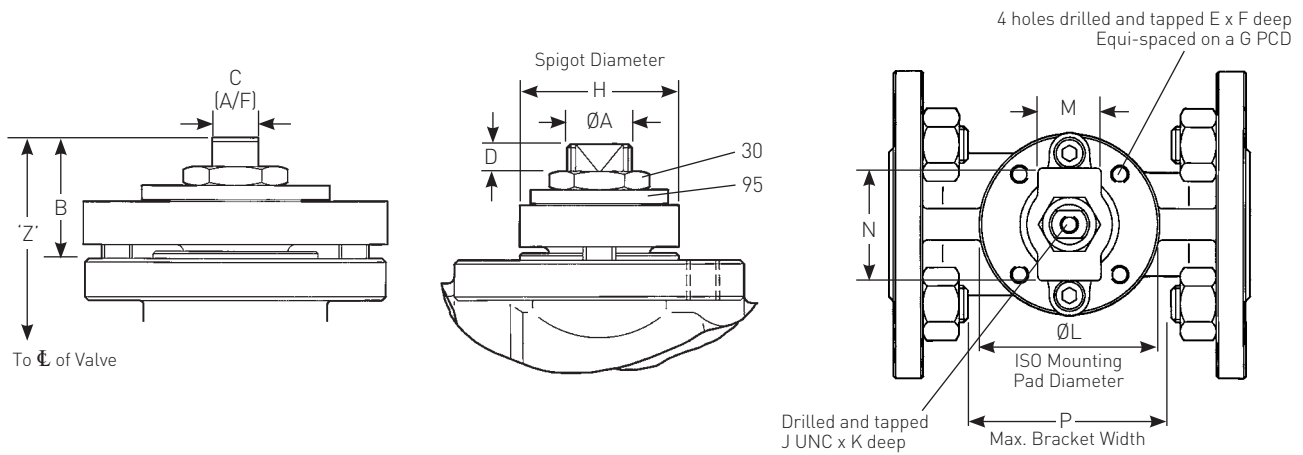

TOPWORKS DIMENSIONS

Shaft size	ISO flange type	A		B		C		D		E	F		G	
		in.	mm	in.	mm	in.	mm	in.	mm		in.	mm	in.	mm
6	F03	0.375/0.372	9.525/9.449	0.714	18.1	0.253/0.250	6.426/6.350	0.138	3.5	M5	0.281	7.1	1.417	36.0
7	F05	0.560/0.557	14.224/14.148	0.989	25.1	0.382/0.379	9.703/9.627	0.250	6.4	M6	0.375	9.5	1.968	50.0

Shaft size	ISO flange type	H		J	K		L		M		N		P(max)	
		in.	mm	in.	in.	mm	in.	mm	in.	mm	in.	mm	in.	mm
6	F03	0.984/0.974	25.00/24.75	No. 8UNC	0.375	9.5	1.875	47.6	0.690	17.5	1 3/16	30.2	1 1/8	41.3
7	F05	1.378/1.368	35.00/34.75	1/4"UNC	0.500	12.7	2.500	63.5	1.020	25.9	1 1/16	39.7	2 1/2	63.5

DIMENSION 'Z'

Valve size		Z	
NPS	DN	in.	mm
1/2	15	1.43	36.3
3/4	20	1.53	38.9
1	25	2.28	57.9
1 1/2	40	2.65	67.3
2	50	2.84	72.1

NOTES

When fitting actuation, please note the following:

1. The stop plate (95) and shaft nut (30) are left in place.
2. Stop screws (93) and stop collars (94) are to be removed before fitting the coupling.
3. The coupling is secured to the valve shaft using the tapped hole in the top of the shaft.

KTM HINDLE SERIES 110 AND 200 ULTRA-SEAL BALL VALVES

PARTS IDENTIFICATION SERIES 200 - REDUCED BORE SOFT SEATED

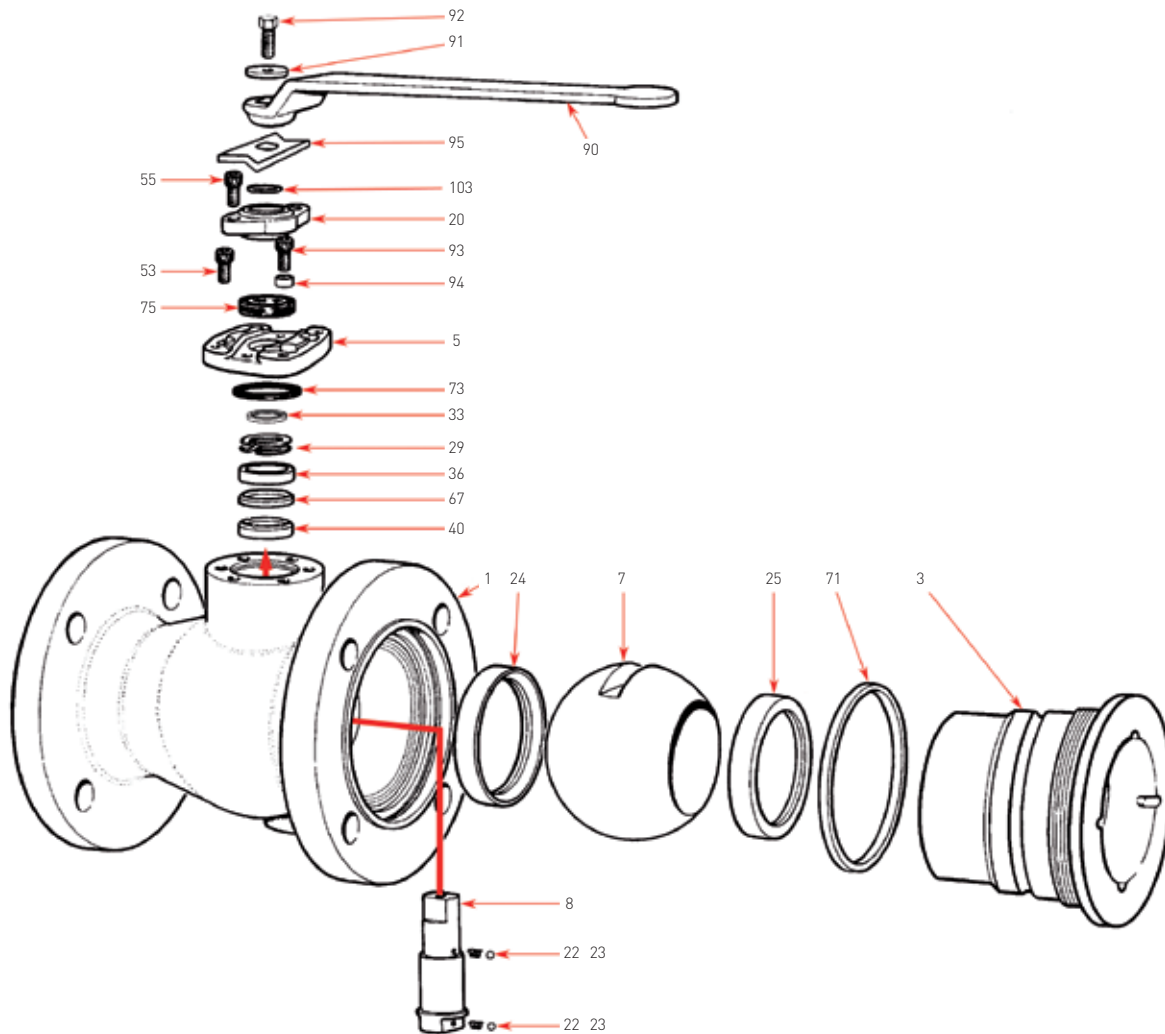

PARTS LIST

Item	Component	Item	Component
1	Body	53	Cover screw
3	Sleeve	55	Gland screw
5	Cover	67	Chevron seal
7	Ball	71	Sleeve seal
8	Shaft	73	Cover seal
20	Gland	75	Shaft fire seal
22	Shaft anti-static ball	90	Handlever
23	Shaft anti-static spring	91	Handlever washer
24	Body seat	92	Handlever screw
25	Sleeve seat	93	Stop screw
29	Gland spring	94	Stop collar
33	Shaft thrust bearing	95	Stop plate
36	Header ring	103	Weather seal
40	Spreader ring		

NOTES

- Standard materials of construction are given on page 14.
- Illustration shown is of a size utilizing valve ISO flange size F07, in which there is one chevron seal ring. All other sizes utilize two chevron seal rings.

KTM HINDLE SERIES 110 AND 200 ULTRA-SEAL BALL VALVES

PARTS IDENTIFICATION SERIES 200 - REDUCED BORE METAL / CARBON SEATED

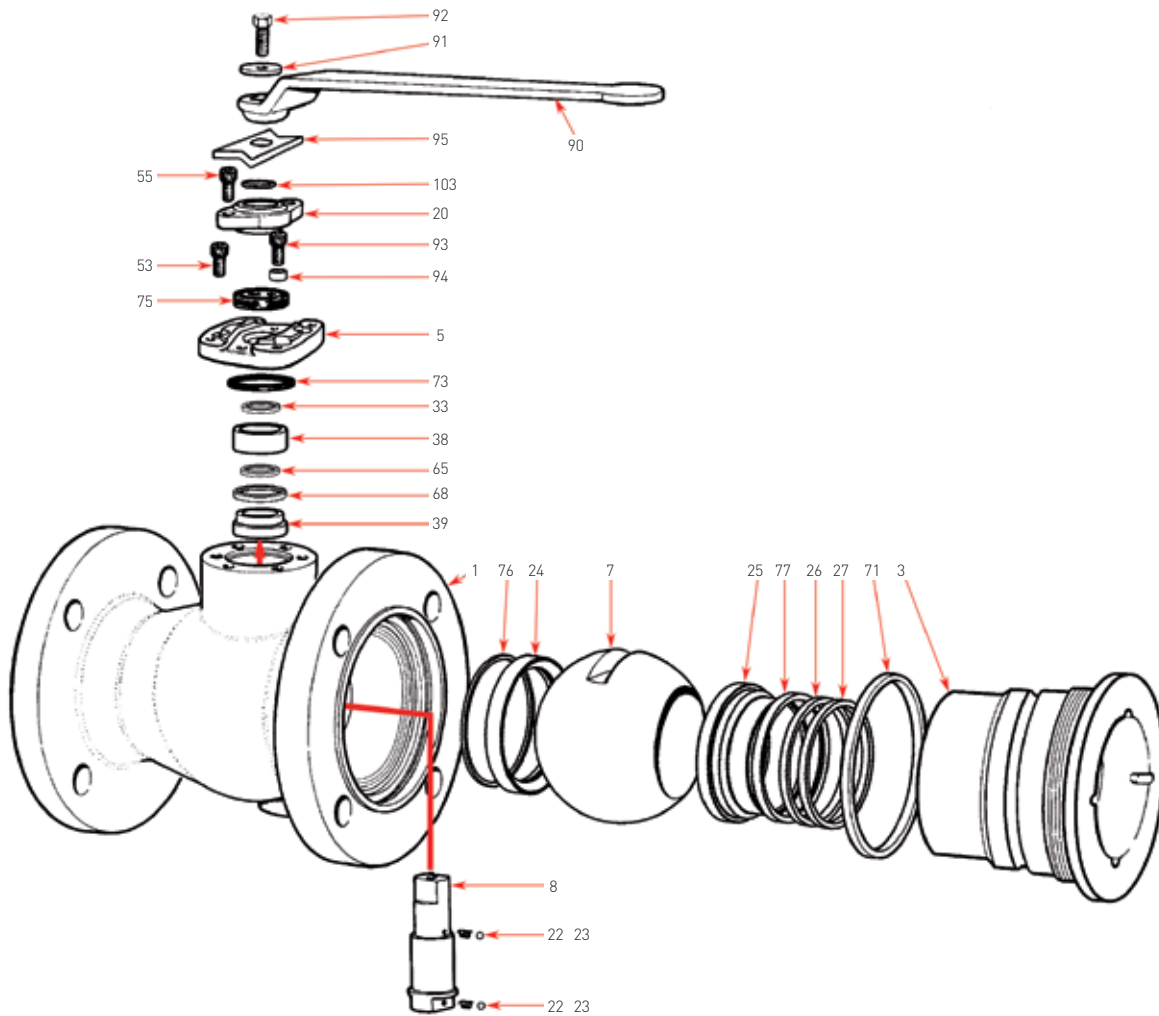

PARTS LIST

Item	Component	Item	Component
1	Body	55	Gland screw
3	Sleeve	65	Shaft primary seal
5	Cover	68	Stuffing box seal
7	Ball	71	Sleeve seal
8	Shaft	73	Cover seal
20	Gland	75	Shaft fire seal
22	Shaft anti-static ball	76	Body seat seal
23	Shaft anti-static spring	77	Sleeve seat seal
24	Body seat	90	Handlever
25	Sleeve seat	91	Handlever washer
26	Seat energizer	92	Handlever screw
27	Seat spring	93	Stop screw
33	Shaft thrust bearing	94	Stop collar
38	Upper stuffing box bush	95	Stop plate
39	Lower stuffing box bush	103	Weather seal
53	Cover screw		

NOTES

- Standard materials of construction are given on page 14.
- Heat dissipation bonnets available for gland isolation outside lagging areas.

KTM HINDLE SERIES 110 AND 200 ULTRA-SEAL BALL VALVES

DIMENSIONS SERIES 200 - REDUCED BORE SOFT SEATED

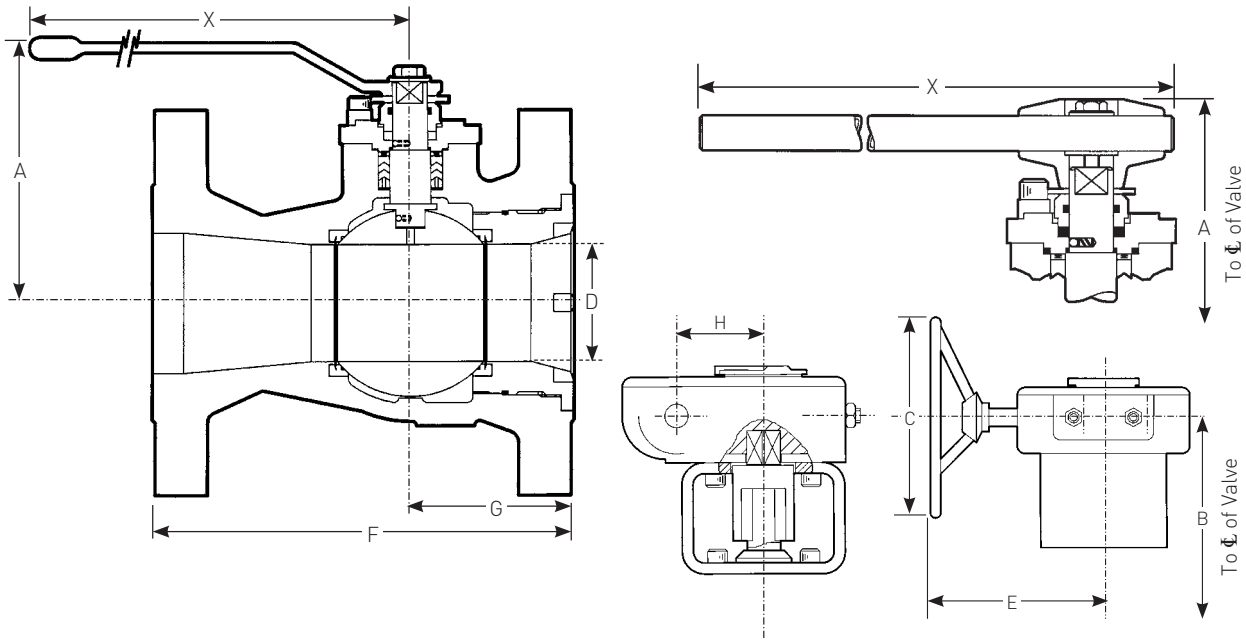

CLASS 150 - MODEL 215R

Size		A		B		C		D		E		F		G		H		X		Weight
NPS	DN	in.	mm	in.	mm	in.	mm	in.	mm	in.	mm	in.	mm	in.	mm	in.	mm	in.	mm	kg
3	80	5 ¹¹ / ₁₆	144.5	-	-	-	-	2 ¹ / ₂	63.5	-	-	8	203.2	3 ¹ / ₂	88.9	-	-	10 ¹ / ₄	260.4	17
4	100	6 ⁵ / ₁₆	160.3	-	-	-	-	3	76.2	-	-	9	228.6	3 ¹ / ₂	88.9	-	-	10 ¹ / ₄	260.4	27
6	150	8 ³ / ₄	222.3	10.24	260	7.87	200	4 ¹ / ₂	114.3	8.58	218	10 ¹ / ₂	266.7	4 ¹ / ₂	114.3	1.77	45	20	508.0	50
8	200	10 ¹ / ₄	260.4	12.20	310	7.87	200	6	152.4	8.66	220	11 ¹ / ₂	292.1	5	127.0	2.80	71	26 ¹ / ₂	673.1	80
10	250	-	-	14.76	375	19.70	500	7 ³ / ₈	187.3	11.34	288	13	330.2	6	152.4	2.80	71	-	-	110

CLASS 300 - MODEL 230R

Size		A		B		C		D		E		F		G		H		X		Weight
NPS	DN	in.	mm	in.	mm	in.	mm	in.	mm	in.	mm	in.	mm	in.	mm	in.	mm	in.	mm	kg
3	80	5 ¹¹ / ₁₆	144.5	-	-	-	-	2 ¹ / ₂	63.5	-	-	11 ¹ / ₈	282.6	3 ¹ / ₂	88.9	-	-	10 ¹ / ₄	260.4	26
4	100	7 ³ / ₄	196.9	-	-	-	-	3	76.2	-	-	12	304.8	4 ¹ / ₄	108.0	-	-	20	508.0	41
6	150	8 ⁷ / ₈	225.4	10.24	260	7.90	200	4 ¹ / ₂	114.3	8.58	218	15 ⁷ / ₈	403.2	4 ¹ / ₂	114.3	1.77	45	20	508.0	76
8	200	10 ³ / ₈	263.5	12.20	310	7.90	200	6	152.4	8.66	220	16 ¹ / ₂	419.1	5	127.0	2.80	71	26 ¹ / ₂	673.1	115
10	250	-	-	14.76	375	19.70	500	7 ³ / ₈	187.3	11.34	288	18	457.2	6	152.4	2.80	71	-	-	160

NOTES

Series 200 Soft Seat

Size Range: Class 150/300 NPS 3 - 10 (DN 80 - 250)

1. The type of operator supplied, as standard, for each size of valve is given on page 2.
2. Face to face dimensions (F in table) conform to ASME B16.10 and BS EN 558.
Details of standard patterns are given on page 2.
3. Top mounting flange details are given on page 13.
4. Flange dimensions conform to ASME B16.5.

KTM HINDLE SERIES 110 AND 200 ULTRA-SEAL BALL VALVES

DIMENSIONS SERIES 200 – REDUCED BORE METAL / CARBON SEATED

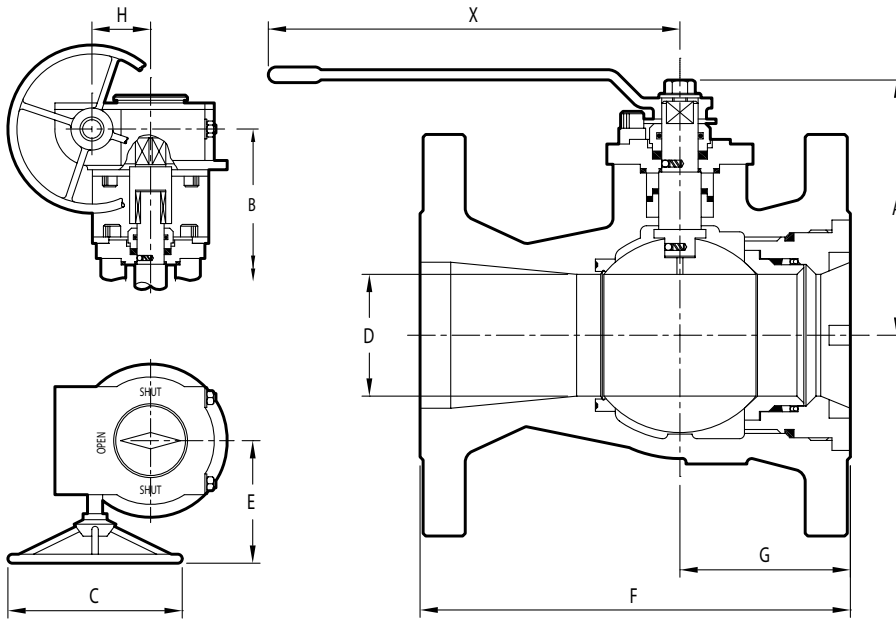

CLASS 150 – MODEL 215RM / 215RC

NPS	DN	A		B		C		D		E		F		G		H		X		Weight kg
		in.	mm	in.	mm	in.	mm	in.	mm	in.	mm	in.	mm	in.	mm	in.	mm	in.	mm	
3 •	80	5 ¹¹ / ₁₆	144.5	-	-	-	-	2 ¹ / ₂	63.5	-	-	8	203.2	3 ¹ / ₂	88.9	-	-	10 ¹ / ₄	260.4	17
4 ••	100	-	-	8	203	7 ⁷ / ₈	200	3	76.2	9 ¹ / ₄	235	9	228.6	3 ¹ / ₂	88.9	1.77	45	-	-	31
6 ••	150	-	-	10 ¹ / ₄	260	7 ⁷ / ₈	200	4 ¹ / ₂	114.3	9 ⁷ / ₈	250	10 ¹ / ₂	266.7	4 ¹ / ₂	114.3	2.80	71	-	-	59
8 ••	200	-	-	12	305	11 ⁷ / ₈	300	6	152.4	10 ¹ / ₂	265	11 ¹ / ₂	292.1	5	127.0	3.38	86	-	-	94

CLASS 300 – MODEL 230RM / 230RC

NPS	DN	A		B		C		D		E		F		G		H		X		Weight kg
		in.	mm	in.	mm	in.	mm	in.	mm	in.	mm	in.	mm	in.	mm	in.	mm	in.	mm	
3 ••	80	-	-	7 ³ / ₈	187	7 ⁷ / ₈	200	2 ¹ / ₂	63.5	9 ¹ / ₄	235	11 ¹ / ₈	282.6	3 ¹ / ₂	88.9	1.77	45	-	-	30
4 ••	100	-	-	9 ¹ / ₈	232	7 ⁷ / ₈	200	3	76.2	9 ⁷ / ₈	250	12	304.8	4 ¹ / ₄	108.0	2.80	71	-	-	50
6 ••	150	-	-	10 ¹ / ₄	260	11 ⁷ / ₈	300	4 ¹ / ₂	114.3	10 ¹ / ₂	265	15 ⁷ / ₈	403.2	4 ¹ / ₂	114.3	3.38	86	-	-	90

NOTES

- Handlever
- Gearbox

Series 200 Metal / Carbon Seat

Size Range: Class 150/300 NPS 3 - 8 (DN 80 - 200)

- The type of operator supplied, as standard, for each size of valve is given on page 2.
- Face to face dimensions (F in table) conform to ASME B16.10 and BS EN 558. Details of standard patterns are given on page 2.
- Top mounting flange details are given on page 13.
- Flange dimensions conform to ASME B16.5.

CLASS 150 - MODEL 215R CLASS 300 - MODEL 230R

Shaft size	Size		Class		K	
	NPS	DN	150	300	in.	mm
1	3	80	215	230	4 ³ / ₄	121
	4	100	215	-	5 ¹³ / ₃₂	137
2	4	100	-	230	6	152
	6	150	215	230	7 ¹ / ₁₆	179
3	8	200	215	230	8 ²¹ / ₃₂	220
4	10	250	215	230	12 ¹¹ / ₁₆	322

KTM HINDLE SERIES 110 AND 200 ULTRA-SEAL BALL VALVES

TOPWORKS DIMENSIONS SERIES 200 - SHAFT SIZES 1, 2, 3

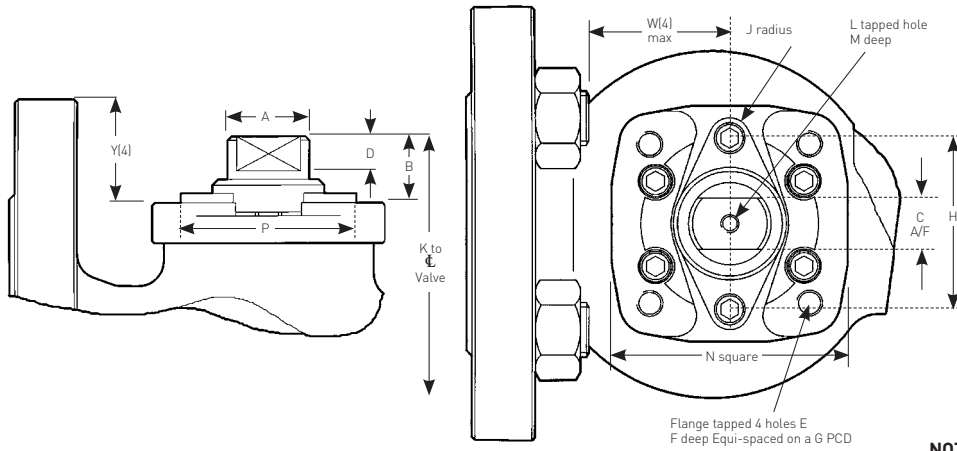

NOTES

- Series 200 utilize four standard shaft sizes.
- Top works dimensions are determined according to the valve shaft size.
- To determine the relevant shaft size for a given valve, refer to table and locate the model concerned by size and pressure rating. Then identify the required dimension.
- Dimensions Y and W are only applicable when height of cover falls below top of flange (as shown). Only these valve sizes are affected. Dimension W is based on bolting to ASME B18.2.2 heavy hex nuts.

TOPWORKS DIMENSIONS SERIES 200 - SHAFT SIZES 4

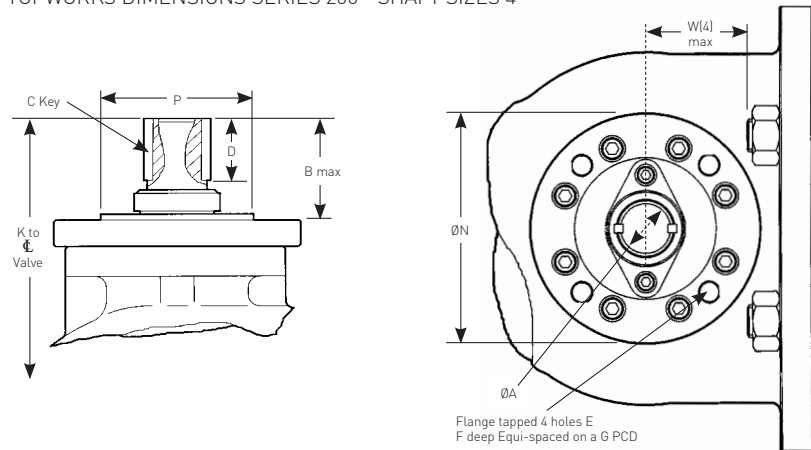

DIMENSIONS

Model 230R		Y		W	
NPS	DN	in.	mm	in.	mm
3	80	0.22	5.5	1.312	33.0
4	100	0.13	3.0	1.866	47.5
6	150	0.32	8.0	2.187	55.5
8	200	0.25	6.0	2.240	57.0

TOPWORKS DIMENSIONS SERIES 200

Shaft size	ISO flange type	A		B		C		D		E		F	
		in.	mm	in.	mm	in.	mm	in.	mm	mm	in.	mm	
1	F07	0.750	19.05	0.820	20.80	0.505	12.83	¹⁵ / ₃₂	12	M8 x 1.25	1/2	12.7	
		0.748	19.00			0.500	12.70						
2	F10	1.125	28.58	1.077	27.40	0.755	19.18	¹⁷ / ₃₂	13	M10 x 1.50	1/2	12.7	
		1.123	28.53			0.750	19.05						
3	F12	1.374	34.90			1.005	25.53	¹³ / ₁₆	20	M12 x 1.75	7/8	22.2	
		1.372	34.85	1.460	37.10	1.000	25.40						
4	F16	1.999	50.78	3.483	88.47	1/2 x 5/16 •		2 1/4	57	M20 x 2.5	7/8	22.2	
		1.997	50.72										

• = Key

N/A = Not available

Shaft size	ISO flange type	G		H		J		L		M		N		P	
		in.	mm	in.	mm	in.	mm	in.	mm	in.	mm	in.	mm		
1	F07	2.250	70	2.093	53.16	5/16	8 UNC	1/4	5/8	16	2 7/8	73.0	2.165	55.0	
													2.160	54.9	
2	F10	4.016	102	3.062	77.77	3/8	10 UNC	5/16	5/8	16	4 1/8	106.0	2.755	70.0	
													2.750	69.9	
3	F12	4.920	125	3.500	88.90	5/8	16 UNC	3/8	3/4	19	4 1/2	114.3	3.345	85.0	
													3.340	84.8	
4	F16	6.496	165	N/A		N/A		N/A	N/A		8.268	210.0	5.115	130.0	

KTM HINDLE SERIES 110 AND 200 ULTRA-SEAL BALL VALVES

PRINCIPAL COMPONENTS

No.	Component	Carbon steel valves	Stainless Steel Valves
1	Body	ASTM A216 WCB ^[1]	ASTM A351 CF8M / CF3M
3	Sleeve	ASTM A216 WCB ^[1]	ASTM A351 CF8M / CF3M
5	Cover	ASTM A216 WCB ^[1]	ASTM A351 CF8M
7	Ball ^{[3][4]}	316/316L stainless steel	316/316L Stainless Steel
7	Ball ^[5]	AISI 316Ti (with hard metal alloy coating)	AISI 316Ti (with hard metal alloy coating)
8	Shaft	316 / 316L stainless steel	316 / 316L Stainless Steel
8	Shaft ^{[4][5]}	17-4 PH	17-4 PH (alternative XM19)
24/25	Seat ring ^[3]	Virgin PTFE	Virgin PTFE
24/25	Seat ring ^[4]	316 / 316L stainless steel (with carbon insert)	316 / 316L Stainless Steel (with carbon insert)
24/25	Seat ring ^[5]	AISI 316Ti (with hard metal alloy coating)	AISI 316Ti (with hard metal alloy coating)

OTHER COMPONENTS

Materials which are common for both carbon steel and stainless steel valves

No.	Component	Material
20	Gland	ASTM A351 CF8M
22	Anti-static ball	ASTM A276-316
23	Anti-static spring	ASTM B164 MONEL 400
26	Sleeve/connector seat energizer	ASTM A276-316 / 316L
27	Seat spring	ASTM A313-631 17-7 PH (up to 350°C) / Alloy A 286 (up to 450°C)
29	Gland spring	17-7 PH stainless steel (up to 350°C) Inconel (above 350°C)
30	Shaft nut	ASTM A240-304H
33	Shaft thrust bearing	PTFE
36	Header ring	PTFE
38	Upper stuffing box bush	ASTM A276-316 and nitrided
39	Lower stuffing box bush	ASTM A276-316 and nitrided
40	Spreader ring	PTFE
53	Cover screw	ASTM A193 B7 / ASTM A193 B8
55	Gland screw	ASTM A193 B7 / ASTM A193 B8
65	Primary shaft seal	25% GF PTFE ^[3] , flexible graphite ^{[4][5]}
67	Chevron seal	PTFE
68	Stuffing box seal	Flexible graphite
71	Sleeve seal ^[3]	PTFE
71	Sleeve seal ^{[4][5]}	Flexible graphite
73	Cover seal	Flexible graphite/316 laminate
75	Shaft fire seal	Flexible graphite
76	Body seat seal	Flexible graphite
77	Sleeve seat seal	Flexible graphite
78	Wiper seal	PTFE ^[3] , flexible graphite ^{[4][5]}
90	Handlever ^[2]	ASTM A576-1035
91	Handlever washer ^[2]	ASTM A240-304H
92	Handlever screw ^[2]	A2-70
93	Stop collar screw ^[2]	A2-70
94	Stop collar	Brass, nickel plated
95	Stop plate	ASTM A276-304
103	Weather seal [Series 110] ^[3]	PTFE
103	Weather seal [Series 200] ^[3]	FKM
103	Weather seal ^{[4][5]}	Flexible graphite
104	T-Bar adapter ^[2]	ASTM A536 65-45-12 / ASTM A351 CF8M
105	T-Bar tube ^[2]	ASTM A573-70
106	T-Bar washer ^[2]	ASTM A240-304H
107	T-Bar screw ^[2]	A2-70

NOTES

- Max. carbon content 0.25%.
 - Operator type varies by size (see pages 7, 11 & 12).
 - Soft seated valves.
 - Carbon seated valves.
 - Metal seated valves.
- Certification is available on standard production, as follows:
- hydrostatic body and seat test.
 - pneumatic seat test.
 - material (chemical and physical) to BS EN 10204 - 3.1.

ALTERNATIVE MATERIALS

Body and trim
Low carbon steel - LCC
Duplex stainless steel
Aluminium bronze
Monel
Other materials available on request.
Seats
Reinforced PTFE
Carbon filled PTFE
TFM 1600
Carbon graphite filled PEEK™

ACCESSORIES

Actuation controls
Locking devices
Lagging extensions

KTM HINDLE SERIES 110 AND 200 ULTRA-SEAL BALL VALVES

PRINCIPAL COMPONENTS

Coating type	Description	Coating thickness	Coating hardness	Temp. limit
HTN-60	Nickel alloy coating	500 micron	60 HRc	450°C
	Flame spraying and fusing			
HTC-70	Chromium carbide coating	200 micron	70 HRc	450°C
	HVOF spray			
HTT-75	Tungsten carbide coating	200 micron	75 HRc approx.	350°C
	HVOF spray			

CARBON GRAPHITE MATERIAL

Carbon graphite type	Description	Density	Coefficient of thermal expansion	Temp. limit
HTCG	Hard carbon graphite A strong antimony impregnated carbon graphite. Suitable for clean organic solvents and purified terephthalic acid (PTA).	2.50 x 10 ³ kg.m ⁻³	4.7 x 10 ⁻⁶ °C	300°C

STANDARD PAINT/FINISH

Carbon Steel Valves

Series 110 Red oxide primer.
Series 200 Red oxide primer.

Stainless Steel Valves

Castings are acid pickled and passivated to remove surface impurities.

Paint Finishes

A range of painting specifications for offshore and onshore service conditions are available to customer requirements.

GRAPH LINE IDENTIFICATION

Size	Seat Material	
	PTFE	RTFE
NPS ½ - 2 DN 15 - 50	B	A
NPS 3 - 6 DN 80 - 150	C	A
NPS 8 DN 200	D	C
NPS 10 DN 250	D	D

PRESSURE/TEMPERATURE GRAPH

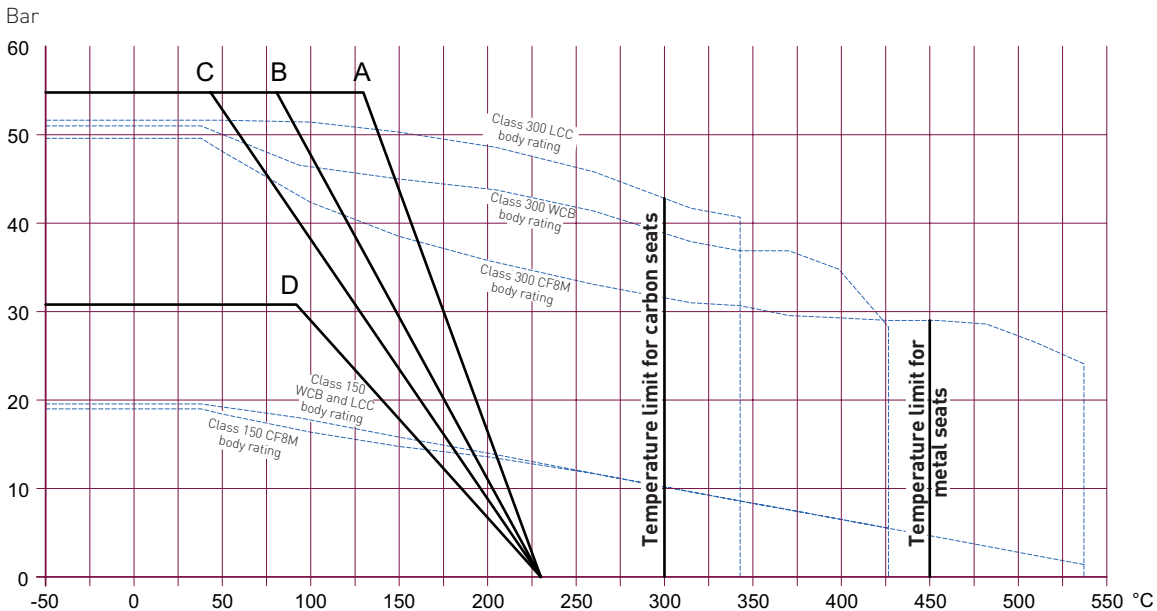

NOTES

- The maximum working capability of any given valve is either the body rating or seat rating, whichever is the lower.
- The Graph Line Identification table indicates the valve seat materials represented by lines A to D on the graph.
- For metal and carbon seats use the maximum body ratings. Carbon seats can only achieve 300°C max.

KTM HINDLE SERIES 110 AND 200 ULTRA-SEAL BALL VALVES

C_v/K_v - VALUES

Valve size			
NPS	DN	C _v	K _v
1/2	15	6	5
3/4	20	10	8.65
1	25	28	24
1 1/2	40	73	63
2	50	110	95
3	80	310	268
4	100	480	415
6	150	1000	865
8	200	1760	1522
10	250	2660	2301

NOTES

1. Flow coefficients are for valves in the fully open position.
2. Ultra-Seal ball valve models are categorised by a four part code indicating design type, ball and seat, flange drilling and body material.
Example given: (215RM - 15 - 316).
3. Other flange drillings available on request.
4. Trim and other component materials for standard valves are given on page 14.

VALVE CODING SYSTEM

Individual model numbers are derived from a combination of:

- Design series number (110, 200)
- Design pressure class (150, 300)
- Ball and seat design (R, RM, RC)
- Flange drilling (ASME 150, 300)
- Body material (161, 316)

SELECTION GUIDE

Example:	2	15	RM	15	316
Series					
1 110					
2 200					
Class					
15 150					
30 300					
Ball/seat design					
R Reduced bore soft					
RM Reduced bore metal					
RC Reduced bore carbon seats					
Flange drilling					
15 ASME 150					
30 ASME 300					
Body material					
316 Stainless steel ASTM A351 CF8M					
161 Carbon steel ASTM A216 WCB					
LCC Carbon steel ASTM A352 LCC					
AB2 Aluminium bronze BS1400 AB2					
DUP Duplex stainless steels					