

DeltaV™ Virtual Machine Controller Simulation

- Minimize controller hardware for development and test
- Avoid control or I/O configuration changes
- Reduce the risk of unexpected problems during commissioning or upgrades
- Improve engineering efficiency and reduce project execution costs
- Accelerate operator readiness and strengthen decision making

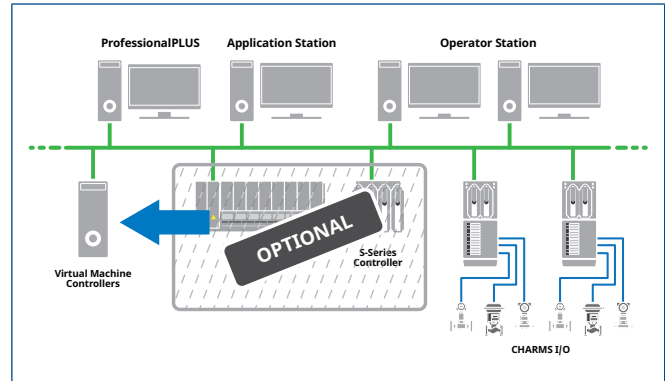

Virtual Machine Controllers run in Host Workstation for Off-line Development and Testing.

Introduction

DeltaV™ Virtual Machine (VM) Controllers for S-Series, M-Series and PK Controllers provide an easy, cost effective way to simulate controller functionality for system development and testing. With these virtual controllers, configuration and I/O assignments can be thoroughly tested without the need for actual controller hardware. This means less physical equipment to set-up and maintain. And the virtual environment makes it easy to add and remove controllers as needed.

In the past, rigorous control system development and testing required physical controllers connected to virtual I/O module (VIM) hardware. Now, the same software used in physical controllers can be run in virtual machines (VMs) in a workstation. These virtual machine controllers, called VM Controllers, can be used for development and testing of the same configuration and I/O assignments used by physical controllers, but without the controller hardware. And unlike control simulation in the DeltaV Application or ProfessionalPlus workstations, the VM Controllers can be configured identically to your physical hardware controllers.

No configuration changes are required between the off-line test system and on-line production system, including I/O assignments and controller node names.

DeltaV VM Controllers also support simulated process I/O for rigorous testing of control applications prior to commissioning. The DeltaV VM Controllers support simulated I/O for both classic I/O and CHARMS based Ethernet I/O cards. Physical or virtual CHARMS I/O cards may be used with the virtual S-Series and PK Controllers. Virtual M-Series Controllers support only simulation for classic I/O.

DeltaV VM Controllers are supported for off-line DeltaV Virtual Studio and VMware based systems, and are available for DeltaV version v14.LTS and higher.

Benefits

Minimize Controller Hardware for Development and Test.

Now you can develop and thoroughly test your control configurations and I/O assignments without control hardware or Virtual I/O Modules (VIMS). DeltaV VM Controllers run in a workstation and support simulated I/O for testing.

Avoid Control or I/O Configuration Changes.

Virtual machine controllers are configured the same as real controllers, including I/O assignments and node names. That means you don't have to reassign modules or bypass I/O during development or FAT, avoiding configuration changes and minimizing the possibility of introducing errors.

Reduce the Risk of Unexpected Problems During Commissioning or Upgrades. Rigorous testing with simulated I/O can uncover configurations errors and avoid costly rework during commissioning. Virtual machine controllers make it easy to thoroughly test applications in a user-friendly workstation environment.

Improve Engineering Efficiency and Reduce Project Execution Costs. Virtualization provides significant efficiency improvement in set up and tear down of systems for development and test. Create new controllers and add them to the DeltaV network in minutes, without wiring or setting up physical hardware. DeltaV VM Controllers save both time and money.

Accelerate Operator Readiness and Strengthen Decision Making. With the addition of snapshot functionality to the VM Controllers based simulate platform, create an efficient operator training simulation system with reduced time for scenario set ups.

Product Description

DeltaV Virtual Machine (VM) Controllers enable you to develop and thoroughly test control configurations without physical controller hardware. They are part of an integrated DeltaV virtualization solution called DeltaV Virtual Studio that makes creating virtual DeltaV systems easy. *For more information, see the DeltaV Virtual Studio product data sheet.* DeltaV VM Controllers are also available for off-line VMware virtualization environments.

DeltaV VM Controllers run in a host computer and are configured to behave the same as physical controllers. Configuration is the same because they use the same software as the physical controller, but the software runs in a virtual machine. When a virtual controller is created and connected to a DeltaV system, it can be commissioned and used for I/O checkout the same way you would use a physical controller.

The DeltaV VM Controllers are completely separate from the DeltaV workstation-based control software (a.k.a., "virtual controller") which allows you to assign and execute modules on a DeltaV Application or ProfessionalPlus workstation. The DeltaV workstation control software requires a full DeltaV workstation to be installed in order to run. The DeltaV VM Controller is an independent controller, just like a physical controller, but runs instead as a virtual machine on a host computer.

For most off-line engineering activities, a VM Controller can be used as a substitute for a physical controller, except that the following features are NOT supported:

- Controller redundancy
- ACN redundancy (i.e., switch over of networks)
- Cold restart (power up configuration) and warm restart (tuning parameter restore)
- Controller diagnostics
- AMS device support
- FOUNDATION Fieldbus

In addition, the VM Controller will not have the same performance metrics because of hardware differences. Specifically, the VM Controller should not be used to test loading. FRETIME, FREMEM, Module Execution Time, and Scan Period may be significantly different between a physical and a virtual controller. Virtual controller loading may also be subject to other operating system scheduling activities.

Application packages that support an OPC interface may be used in the DeltaV Simulate environment. For example, the OPC version of the Mimic™ process simulation may be used with DeltaV Simulate for automation system checkout and operator training. The Mimic OPC interface uses the simulate capability of the DeltaV system and I/O blocks.

VM Controller I/O Simulation Capability

An important capability of the VM Controller is the ability to use simulated I/O with the same I/O assignments and/or Device Signal Tags (DST) used by physical I/O cards and controllers. The Virtual S-Series and PK Controller supports simulated I/O for both Classic I/O and CHARMS I/O cards. The Virtual M-Series Controller only supports simulated I/O for Classic I/O.

Subscription Based VM Controller I/O Simulation Capability

Starting DeltaV v15.LTS, Virtual Machine Controllers (M-Series, S-Series and PK Virtual Machine Controllers) will be available for purchase in subscription-only licensing for new systems.

In DeltaV v15.FP1 a new subscription base VM PK Flex Controller, is introduced which has the same capabilities of a VM PK Controller and same support of simulated I/O for both Classic I/O and CHARMS I/O cards.

The subscription-based licensing (see licensing section for details), will allow you to reduce the upfront capital investment for a simulation environment and will also allow you to avail flexible term lengths allowing you to purchase only what is needed.

CHARMS I/O Simulation

CHARMS I/O signals can be simulated with or without a CHARM I/O card. Starting in DeltaV v14, you can simulate CHARMS I/O signals without a CHARMS I/O card by reading and writing to Device Signal Parameters using DST tag names referenced in your control modules. Access to Device Signal Parameters is provided through a DeltaV I/O Simulate Application or via OPC. Simulation via DST tag names enable you to read and write device parameters without knowing physical I/O assignments which are not always available during development and testing. Device Signal Parameter simulation is only available with DeltaV VM Controllers and not supported with physical controllers.

Simulated CHARMS I/O Cards

CHARMS I/O can also be simulated with either physical or virtual CHARMS I/O Cards. You can read and write to primary parameter and status fields using the DeltaV's CHARMS Simulate application or with Mimic process simulation application. The virtual CHARMS I/O Card is supported for both DeltaV Virtual Studio and VMware environments and is easily interfaced with the Virtual S-Series and PK Controllers through a standard DeltaV ACN Ethernet connection. *For more information, see the product data sheet for DeltaV Virtual CHARM I/O Card Simulation.*

Conventional I/O Simulation

Simulation of conventional I/O for DeltaV VM Controllers is supported via I/O channel address or device signal parameters DST tag names. For simulation via I/O channel address, you can read and write to primary parameter and status fields via OPC applications like DeltaV Watchit or Mimic, or via parameter references in DeltaV function blocks. A typical OPC path for a conventional I/O channel address would be <node name>/IO1/<card number>/<channel number>/<field parameter name>. Table 1 lists the supported I/O channel types and parameters for conventional I/O simulation via I/O channel address.

Conventional I/O simulation is only available with DeltaV VM Controllers and not supported with physical controllers.

DST Simulation

Starting in DeltaV v14, you can also simulate I/O signals (for CHARMS and conventional I/O) by reading and writing to Device Signal Parameter using DST tag name references. Access to Device Signal Parameters is provided through a DeltaV I/O Simulate Application or via OPC. Simulation via DST tag names enable you to read and write device parameters without knowing physical I/O assignments. A typical OPC path for a Device Signal Parameter DST tag name reference would be '*<device DST Tag name>/<field parameter name>' (for example, *LT-101/FIELD_VAL_PCT). Table 2 lists the supported function block types and parameters for I/O simulation using device signal tag (DST) name references.

In addition to supporting DST simulation for CHARMS, conventional I/Os, Profibus and DeviceNet, starting in DeltaV v15.LTS, the DST simulation capability has been extended to cover more I/O types including Serial I/O, Modbus TCP, EtherNet/IP and OPC UA Client.

DeltaV v15.LTS supports EtherNet/IP, Modbus TCP and Serial I/O in virtual PK Controller; Serial I/O in virtual M/S series controllers; and EtherNet/IP, Modbus TCP and OPC UA Client in virtual EIOC.

Table 1 – Supported I/O Channel Types and Parameters for Conventional I/O Simulation	
Channel Type	Field Parameter
Analog Input	FIELD_VAL_PCT
HART Analog Input	HART_FIELD_VAL
Analog Output	OUT
HART Analog Output	OUT
Discrete Input	FIELD_VAL_D
Pulse Count Input	COUNTER_IN
Pulse Input	COUNTER_IN FREQUENCY
Discrete Output	OUT_D
Continuous Pulse Output	ONTIME
Momentary Output	OUT_D
RTD, Thermocouple, Voltage, and mV types	FIELD_VAL FIELD_VAL_PCT
SOE Discrete Input	FIELD_VAL_D

Table 2 – Supported Function Block Types and Parameters for I/O Simulation Using Device Signal Tag (DST) References	
Supported Function Block Types	Supported Simulated Parameters
<ul style="list-style-type: none"> ■ AI ■ AO ■ DI ■ DO ■ PID ■ PIN 	<ul style="list-style-type: none"> ■ DC ■ EDC ■ LSAI ■ SLDVC ■ LSDI ■ LSDO
	<ul style="list-style-type: none"> ■ FIELD_VAL_PCT ■ HART_FIELD_VAL ■ FIELD_VAL ■ COUNTER_IN ■ FREQUENCY ■ OUT ■ ON_TIME ■ FIELD_VAL_D ■ OUT_D

VM Controller I/O Channel Simulation Limitations

The virtual I/O channel simulation provided with the VM Controller does not support the following features:

- **Remote I/O.** The simulation of remote I/O such as Wireless Devices, Zone1 and Zone2 I/O are not supported through the direct virtual I/O parameter references.

- **Bussed I/O.** The simulation of bussed I/O such as Fieldbus and IEC61850 is not supported through virtual I/O simulation.
- **DeltaV™ Diagnostics.** Simulated I/O does not replicate all field device behavior (only the signal value); therefore, it is impossible to have valid diagnostic data from the virtual I/O channels. Diagnostic utilities such as DeltaV Diagnostics should not be expected to provide accurate information.

■ **Advanced I/O Card Features.** Advanced features that may be available on some real I/O cards will not be supported for simulated I/O. This includes redundant card operation, card maintenance port access, railbus statistics, card status and card integrity. Certain advanced channel features must be taken into account during I/O virtualization. This includes secondary parameters such as the FREQUENCY parameter of a pulse input channel. The FREQUENCY parameter is normally calculated by the I/O card, so the virtualization configuration must provide that information for a DeltaV configuration utilizing FREQUENCY to work properly. Other passive channel configurations must similarly be taken into account with the virtualization configuration including cold junction compensation, linefault detection, pulse period, I/O filters, debouncing options, and any actions taken on a channel value reset. Other advanced channel features not supported include SOE Event Generation, SOE Chatter Control, and digital HART functionality.

DeltaV™ Virtual Studio

DeltaV Virtual Studio is an integrated DeltaV application environment designed for easy implementation and management of virtual DeltaV control systems for both off-line and on-line production systems. DeltaV Virtual Studio is used to create, modify, start, stop, and move DeltaV virtual machines. DeltaV VM Controllers are easily created and assigned to host computers using DeltaV Virtual Studio. Figure 2 shows the DeltaV Virtual Studio application.

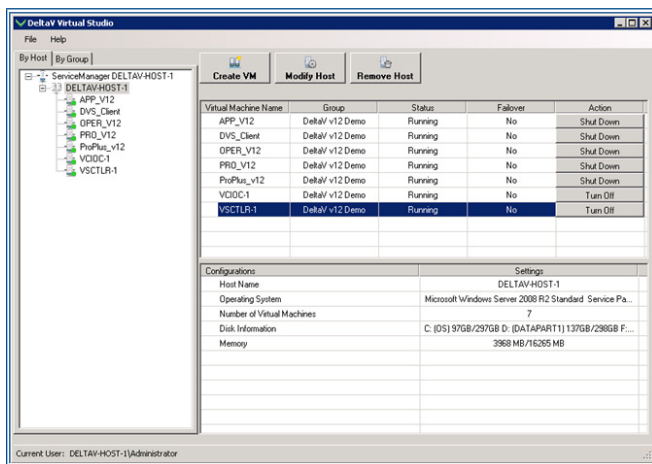

Figure 2. DeltaV™ Virtual Studio Application.

DeltaV VM Controllers are easy to create and implement using virtual machine templates. These templates allow you to easily add controllers from a single configuration dialog. Simply specify the host computer, enter a controller name, select the DeltaV VM Controller template, select the network connections from a drop down menu, and press OK. Within a minute or two the new controller will be automatically generated from a prebuilt template. For more information, see the product data sheet for DeltaV Virtual Studio.

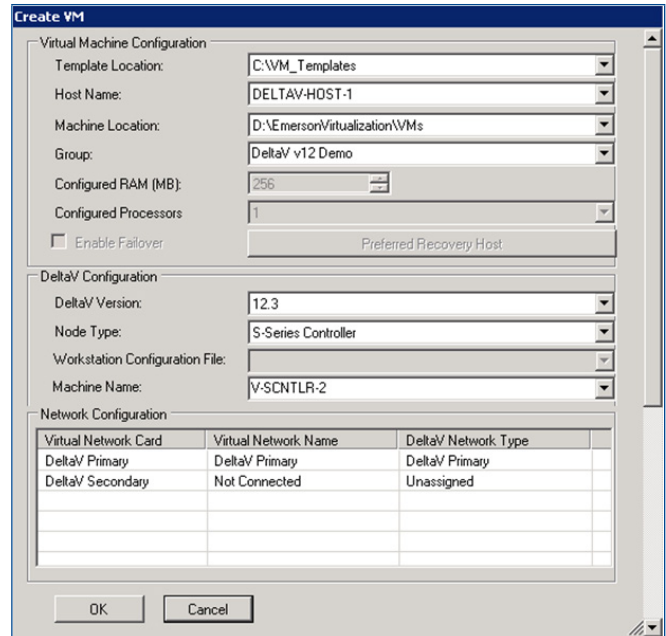

Figure 3. Creating a Virtual S-Series Controller.

Licensing

DeltaV VM Controllers (Virtual M-Series, Virtual S-Series, Virtual PK, Virtual PK Flex) are licensed per VM Controller for a specific DeltaV system ID and may be used for off-line simulation only. A base license must be purchased and then additional VM Controller licenses can be added. The licenses are sold in quantities of 1, 5, 10, and 20 as described below.

Subscription Based Licensing

DeltaV VM Controller licensing for Virtual M-Series, S-Series and PK starting DeltaV v15.LTS and Virtual PK Flex licensing starting v15.FP1 can be only purchased as a one-year, three-year, or five-year subscription which includes software licensing, updates, and support. The subscription licenses are sold in quantities of 1, 5, 10, and 20 VM Controllers as described in table below.

For the snapshot functionality, available starting v15.FP3 DeltaV SimulatePro for VM Controllers, Multi-Node, licensing is available for purchase as a one-year, three-year or five-year subscription which includes software licensing, updates, and support. Please note that the number of DeltaV SimulatePro for VM Controller licenses should equal the number of VM Controller licenses. A VM Controller based Simulate system requiring snapshot functionality will also require licenses for DeltaV SimulatePro for Workstations (PPN/ASNs). The number of SimulatePro licenses should equal the number of workstation nodes – PPN and ASN(s) in the VM controller simulate solution from where the SimulatePro utility will be used/snapshots will be taken.

The expiration date of the VM PK Flex licensing can be found in the system licensing summary. Customers will get reminded via email to renew subscription.

To view the expiration of the Simulate Multi-Node system ID (including M-Series, S-Series and PK VM Controllers) launch Watchit application and use the DongleDriver path. The expiration will appear along with the system ID.

If a VM Controller software license is allowed to expire, the continued use of the software is not permitted. The VM Controller software will continue running the currently loaded configuration in this unlicensed state, but you will not be able to download any changed configuration to the unlicensed VM Controller.

Please contact your sales representative to know more about the subscription contract process.

Support of Ethernet Protocols with DeltaV™ VM PK and VM PK Flex Controllers

For better functionality when using ethernet devices, the use of Modbus TCP client or EtherNet/IP interface in port P01 and PROFINET in port PN1 is supported in the VM PK and VM PK Flex Controllers (Modbus TCP server and OPC UA server are not supported) with the use of simplex networking (Advance networking in the ports of the VM PK

and VM PK Flex Controllers will not be allowed, preventing the use of bonding and bridging, Parallel Redundant Protocol (PRP) or connecting to an MRP ring topology).

Capacities

Sizing for DeltaV VM Controllers is based on the largest available model (i.e., SX, MX, and PK1500 Controllers) and contain a superset of all functionality for their respective controller series. The recommended maximum number of VM Controllers is 20 per host computer, dependent on host computer resources. See *DeltaV Virtual Studio product data sheet for System Planning Guidelines*.

Snapshot Functionality for the VM Controllers

DeltaV Snapshot functionality comprising of pause, save, restore and resume functions is available for the Virtual Machine Controller based Simulate solution for Operator training purposes. This will be available for both BPCS and SIS VM Controllers – vPK, vS-Series, vM-Series, vEIOC, and vSZ/vCSLS. Please note, this functionality is available starting DeltaV v15.FP3 and in addition will also require an install of “DeltaV Snapshot – For VM Controllers” workstation bundle and VM embedded node templates.

The time taken for save and restore (snapshot) operations can vary depending on factors such as the number of virtual machine controller nodes, number of vCSLSs per vSZ, and the complexity of the DeltaV configuration. As a result, snapshot performance may differ across various system architectures.

To ensure optimal responsiveness, it is recommended to select no more than four virtual BPCS nodes at a time.

For vSZ, we recommend taking snapshots of one virtual SZ controller at a time for the best performance results.

Please also refer the information mentioned in the Prerequisites section of this PDS for details on licensing and solution requirements.

Please note, this snapshot functionality and the associated SimulatePro licensing does not support speed up & slow down and record and playback operations.

Ordering Information *

Description	Perpetual Model Number	Subscription Model Number
DeltaV™ Virtual Machine (VM) Controller Licensing		
DeltaV Simulate S-Series, M-Series VM Controller (Base License)	VX1019S001	VX1019SwS001_YyFYzz
DeltaV Simulate S-Series, M-Series VM Controller Scale-up, 1 VM Controller	VX1019UPS01	VX1019SwUPS01_YyFYzz
DeltaV Simulate S-Series, M-Series VM Controller Scale-up, 5 VM Controllers	VX1019UPS05	VX1019SwUPS05_YyFYzz
DeltaV Simulate S-Series, M-Series VM Controller Scale-up, 10 VM Controllers	VX1019UPS10	VX1019SwUPS10_YyFYzz
DeltaV Simulate S-Series, M-Series VM Controller Scale-up, 20 VM Controllers	VX1019UPS20	VX1019SwUPS20_YyFYzz
DeltaV Simulate PK VM Controller (Base License)	VX1021S001	VX1021SwS001_YyFYzz
DeltaV Simulate PK VM Controller Scale-up, 1 VM Controller	VX1021UPS01	VX1021SwUPS01_YyFYzz
DeltaV Simulate PK VM Controller Scale-up, 5 VM Controllers	VX1021UPS05	VX1021SwUPS05_YyFYzz
DeltaV Simulate PK VM Controller Scale-up, 10 VM Controllers	VX1021UPS10	VX1021SwUPS10_YyFYzz
DeltaV Simulate PK VM Controller Scale-up, 20 VM Controllers	VX1021UPS20	VX1021SwUPS20_YyFYzz
DeltaV SimulatePro for Workstations (PPN/ASNs) in VM Controller Simulate Solution		
DeltaV SimulatePro Utility, Multi-Node, w-Year Subscription; 1 SimulatePro Workstation License for use with SimulatePro for VM Controller	Not Applicable	VX2207SwUS001_YyFYzz
DeltaV SimulatePro Licensing for VM Controllers		
PK Flex Controller VM w-Year Subscription for use with DeltaV Simulate Multi-Node; xx PK Flex Controller VM License	Not Applicable	VX1022SwSxx_YyFYzz
DeltaV SimulatePro for VM Controller, Multi-Node; License for use with 1 VM Controller on a Simulate Multi-Node System with Subscription Licensing	Not Applicable	VX1024PSwS001_YyFYzz
DeltaV SimulatePro for VM Controller, Multi-Node; License for use with 5 VM Controllers on a Simulate Multi-Node System with Subscription Licensing	Not Applicable	VX1024PSwS005_YyFYzz
DeltaV SimulatePro for VM Controller, Multi-Node; License for use with 10 VM Controllers on a Simulate Multi-Node System with Subscription Licensing	Not Applicable	VX1024PSwS010_YyFYzz
DeltaV SimulatePro for VM Controller, Multi-Node; License for use with 20 VM Controllers on a Simulate Multi-Node System with Subscription Licensing	Not Applicable	VX1024PSwS020_YyFYzz

Description	Perpetual Model Number	Subscription Model Number
DeltaV SimulatePro for VM Controller, Multi-Node; License for use with 1 VM Controller on a Simulate Multi-Node System with Perpetual Licensing	Not Applicable	VX1024SSwS001_YyFYzz
DeltaV SimulatePro for VM Controller, Multi-Node; License for use with 5 VM Controllers on a Simulate Multi-Node System with Perpetual Licensing	Not Applicable	VX1024SSwS005_YyFYzz
DeltaV SimulatePro for VM Controller, Multi-Node; License for use with 10 VM Controllers on a Simulate Multi-Node System with Perpetual Licensing	Not Applicable	VX1024SSwS010_YyFYzz
DeltaV SimulatePro for VM Controller, Multi-Node; License for use with 20 VM Controllers on a Simulate Multi-Node System with Perpetual Licensing	Not Applicable	VX1024SSwS020_YyFYzz

Note: DeltaV™ SimulatePro for VM Controller, Multi-Node licenses as well as the solution does not include support for speed up and slowdown, Record and Playback functionalities.

*Ordering Information is for licenses only. Virtual Machine Controller software is provided with the media kits as described in the DeltaV Virtual Studio product data sheet.

Simulate Multi-Node software licensing starting DeltaV v15.LTS can be only purchased as a one-year, three-year, or five-year subscription which includes software, updates, and support.

These model numbers are for initial subscriptions only; model numbers for renewals are listed separately in the price book.

*w represents the length of the subscription term in years (1, 3, or 5).

*y represents the specific year of the subscription term (1, 2, 3, 4, or 5).

*zz represents a two-digit indicator of the year of purchase (e.g. 23).

*xx represent the bundle size for PK Flex VM Controllers (1,5,10 or 20).

For existing customers with perpetual Simulate Multi-Node licenses who wish to expand and/or upgrade their DeltaV Simulate Virtual Machine Controllers, please contact your local sales office.

Prerequisites

- DeltaV v11.3.1 or later is required for S-Series and M-Series VM Controllers. DeltaV v14 or later is required for PK VM Controllers.
- DeltaV v15.FP1 or later for VM PK Flex.
- DeltaV v15.LTS or later required for Subscription-Based licensing for M-Series, S-Series and PK VM Controllers.
- Please consider appropriate number of Application stations to support the required OPC data traffic for the VM controller based simulate solution/architecture.
- DeltaV v15.FP3 or later is required for the new snapshot functionality (pause, save, restore & resume) for the VM Controllers based simulate solution. In addition, the user will be required to install the “DeltaV Snapshot – For VM Controllers” workstation bundle with v15.FP3 along with the VM Controller templates. Please refer to the Ordering Information table in the document for part number details.
- A VM Controller based Simulate system requiring snapshot functionality will require the number of DeltaV SimulatePro for VM Controller licenses to equal the number of VM Controller licenses.
- A VM Controller based Simulate system requiring snapshot functionality will also require licenses for DeltaV SimulatePro for Workstations (PPN/ASNs). The number of SimulatePro for workstation licenses should equal the number of workstation nodes – PPN and ASN(s) in the VM Controller simulate solution from where the SimulatePro utility will be used/snapshots will be taken. The part numbers are mentioned in the Ordering Table of this PDS.
- App stations/Pro Plus running Batch Executives will continue to require SimulatePro licenses. In addition, please note that to ensure appropriate functioning of the snapshot functionality, a control module will need to be assigned and run on that APP station(s) and/or ProPlus where the Batch Executive is running.

Related Products

- **DeltaV SIS with Electronic Marshalling Virtual Simulation.** Provides virtualization of SIS hardware components for rigorous testing of CSLS safety logic and operator graphics. *For more information see product data sheet for DeltaV SIS with Electronic Marshalling – Virtual Simulation.*
- **DeltaV Virtual Studio.** An integrated DeltaV application environment designed for easy implementation and management of virtual DeltaV control systems for both off-line and on-line production systems. Virtual machine templates are provided for automatic generation and configuration of DeltaV workstations and controller hardware. *For more information, see product data sheet for DeltaV Virtual Studio.*
- **DeltaV Virtual CHARMS I/O Card Simulation.** Simulation of process I/O using virtual CHARMS I/O cards running in a workstation PC. Virtual CHARMS I/O cards provide the same simulation capability as real CHARMS I/O cards and can be used for rigorous checkout of I/O assignments, operator displays, and control functionality. Available for both DeltaV Virtual Studio and VMware environments. *For more information, see product data sheet for DeltaV Virtual CHARMS I/O Simulation.*

- **Mimic™ Simulator.** Supports both simple tie-back simulation and rigorous first principle process simulation. Mimic has special I/O drivers developed to support DeltaV VM Controllers. *Refer to Mimic product data sheets for more information.*

Related Hardware Products

- **DeltaV Virtualization Hardware.** Thoroughly tested and supported computer and peripheral devices for use with DeltaV Virtual Studio. Hardware includes host servers, thin clients, network switches, and related hardware required for DeltaV Virtualization. *For more information, see product data sheet for DeltaV Virtualization Hardware.*

Related 3rd Party Products

- **VMware Workstation and ESXi Hypervisor.** DeltaV Virtual S-Series, M-Series and PK Controllers are available and supported for VMware environments.

©2025, Emerson. All rights reserved.

The Emerson logo is a trademark and service mark of Emerson Electric Co. The DeltaV logo is a mark of one of the Emerson family of companies. All other marks are the property of their respective owners.

The contents of this publication are presented for informational purposes only, and while diligent efforts were made to ensure their accuracy, they are not to be construed as warranties or guarantees, express or implied, regarding the products or services described herein or their use or applicability. All sales are governed by our terms and conditions, which are available on request. We reserve the right to modify or improve the designs or specifications of our products at any time without notice.

Contact Us

🌐 www.emerson.com/contactus